

CRITICAL CONSIDERATION AND IMPROVEMENT OF THE FMEA

Alois J. Breiing

Center of Product Development
Swiss Federal Institute of Technology Zurich
Switzerland
breiing@imes.mavt.ethz.ch

Andreas M. Kunz

Center of Product Development
Swiss Federal Institute of Technology Zurich
Switzerland
kunz@imes.mavt.ethz.ch

ABSTRACT

The FMEA = Failure Mode and Effect Analysis [10], [15] is a method to recognize and to eliminate mistakes already during the product design process and in particular in the earliest stages. Carried out consistently, many mistakes and/or sources of errors can be detected and eliminated with this method. Since the FMEA does not detect all mistakes and/or sources of error in the product development process and does not consider the human being during the usage phase (i.e. from startup to disposal of a product) as a source of error it is not yet satisfactory regarding effectiveness and efficiency. Thus the FMEA is still not completely accepted. The proposed paper presents ideas and approaches how these problems mentioned above can be encountered and which influences and/or changes derive from that for future FMEA-sessions.

KEYWORDS

FMEA (Failure Mode and Effect Analysis), failures of human being, project team, heuristic context of failures, product development process, use analysis, development process, market launch, product usage stage, product recycling and liquidation.

1. INTRODUCTION

The FMEA method was developed in the sixties (exactly in the year 1963 by NASA within the Apollo mission) to design products without design

failures. This is especially important when products can not be repaired easily, e.g. satellites or space-ships. The method was adopted later from the aviation industry, the automotive industry, the medicine and nuclear technology as well as from the armaments industry [9], [15]. In addition this method is more and more used in all fields of the development process of consumer and capital goods [3], [10], [13], [18]. With the increasing circulation of this method it was further developed in small steps. Today this method is applicable on almost every product. It is schematized and formalized as it is shown in Figure 1.

It can be distinguished between a system-FMEA, a design-FMEA and a process-FMEA, that all take place in the product development process. Preliminary stages as well as the phases after the market launch are not considered yet.

The system-FMEA examines the systematical context between a product and its integration into a system. This method is mainly used in the concept phase and in the design phase. The design-FMEA is mainly used in the development phase and searches for constructive mistakes. The process-FMEA is

Fehler-Möglichkeiten und Einfluss-Analyse (Failure Mode and Effect Analysis - FMEA)										Name of function, working principle and assembly: Ident-No.:				
Generating department										Generated by: Date:				
Failure location Ident-No.	Type of failure	Impact of failure	Cause of failure	Present status					Remedial action	Improved status				
				Means of control	A	B	E	RPZ		Realized actions	A	B	E	RPZ
1	2	3	4	5	6	7	8	9	10	11	12	13	14	15

Figure 1. Form of the conventional FMEA (from: VDI)

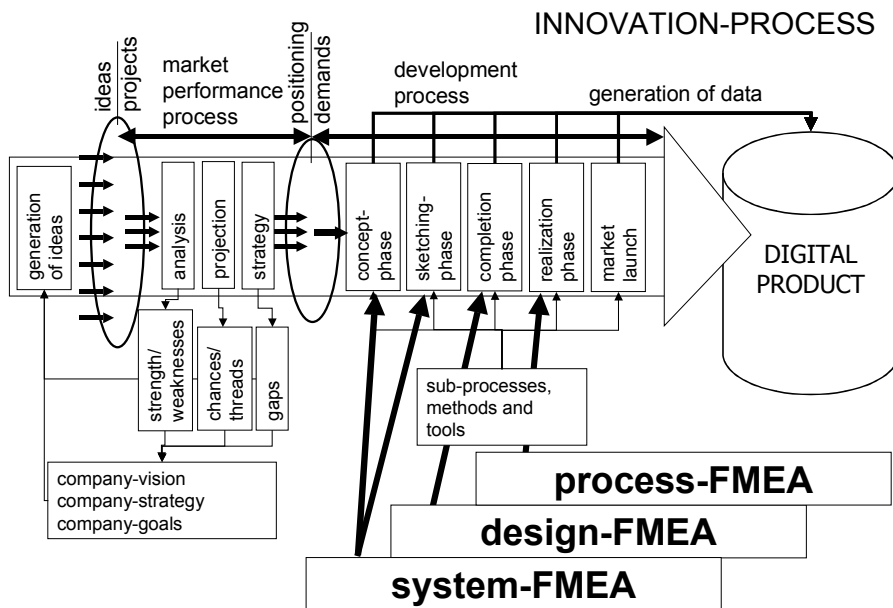

Figure 2. Integration of the FMEA methods into the product development process (from: ETHZ)

used in the realization phase and examines mainly the production process (manufacturing and assembling process) of a product. All three FMEA-methods are carried out independently from each other by different teams [14]. Figure 2 gives an overview on the product development process and how the FMEA-methods are integrated into it.

The complexity of many products through their mechatronic character but also through the used simultaneous engineering complicates to distinguish between the different FMEA-methods. In addition many FMEA-sessions mix up all three fields [14]. Therefore it has to be considered whether the subdivision in different FMEA-processes (Figure 2) is reasonable. In addition to this product-related view the method has to be extended by new questions and ideas. This will be necessary because of the approximation of product design (in the meaning of shaping and modeling) to the conventional method of the construction process.

2. GENERAL WEAKNESSES OF THE FMEA

First of all, some of the reasons are considered that hinder the acceptance of the FMEA in industry (see also [14]).

1. The prerequisites for a FMEA are not met and thus the partial knowledge results in unrecognized errors. The following

prerequisites must be met at the beginning of a FMEA:

- FMEA participants that are competent and confirmed in their continuity (see [5] and [6]).
- the product idea is understandably defined to all FMEA participants.
- the market performance process of a new product.
- a list of demands that is tested for relations among the demands and that is cleaned up (see [7]).
- the use analysis (see [4]).
- a functional analysis, if possible in the shape of a functional diagram.
- a complete documentation of the stage of development.

2. The methodic context between the individual components and units as well as outer (referring to the usage of a product) and inner functions (working principles, effects and regularities) (see Figure 3) can not be correctly represented in conventional forms. This will result in wrong decisions.

Under this aspect the question becomes obsolete how column 1 of an FMEA-form is structured. First of all the functional structure (outer and inner functions) has to be entered, followed by the components and modules. The question has to be answered how they

Action	operate	view	hear
Function	amplify	shine	ring
Principle	hydraulic	electric	acoustic
Effect, phys. principle	static pressure	Ohm's law	sound wave
Formula	$P_2 = P_1 \cdot (A_2/A_1)$	$U = R \cdot I$	$E = J / (f \cdot \lambda)$

Figure 3. Heuristic context within the product development process; solution finding in the concept stage in 5 stages (from: Breiing)

fulfill the needed actions from figure 3. Finally the producibility and the production process are examined (see figure 4).

3. The (formal) FMEA with conventional forms [10] is in principle very incomplete since a suitable inspection of the completeness is not given. This takes effect on the already mentioned methodic context and on the other hand on the accidental error recognition. Some influences for the improvement of the error recognition:
 - Experiences of the FMEA-participants.
 - Integrate other specialists.
 - Knowing or becoming acquainted of the product to be analyzed.
 - Neural nets learn too (see [17]).
 - Integration of the customer-oriented departments and the customers themselves.
 - Collection of mistakes and assigned experiences in databases.
 - Studying the history of a product (test reports, complaint reports etc.).
 - Concurrent application of heuristics supporting tools, for example *Invention-Machine*.
4. The FMEA with conventional forms requires many text repetitions and thus a large amount of documentation and required time, in particular if a separation into different FMEA methods is done. In addition many unreadable FMEA-"books" will result from that [14]. Improvement could be done with
 - a) computer supported FMEA sessions or
 - b) perhaps the Matrix-FMEA [14].
5. The FMEA elements (entities) of the different methods (system-, design-, process-FMEA) are not defined unambiguously and thus application synergies can not be used. Thus the separation into the different FMEA methods should be abolished since it can not be done consistently anyhow (see Figure 6).
6. The FMEA refers only to hardware, not onto documentation, services, software logistics, test programs, manufacturing means, production plants and machines. Measurement- and checking facilities, experimental setups and devices are not covered

by any FMEA although many errors could occur here. This situation only can be improved by including these new fields.

7. The different FMEA methods (working levels [14]) are processed by different persons [14] and thus a continuity of the mistake recognition and elimination becomes almost impossible. If there is a continuity of the participating team-members also a continuity in the workflow is guaranteed. In addition that would have the advantage that all members become more acquainted with the product.
8. The definition of the RPZ-numbers is done subjectively and thus randomly. Therefore the selection of the FMEA-participants has to be done carefully in order to take into account the different views and aspects and to gain a realistic RPZ. This problematic is similar to the one of the evaluation process (see [5] and [6]).

3. NEW APPROACHES

In this paragraph the weak points 4 to 7 are illuminated and improvements of the described situations are proposed.

The observation of carried out FMEA sessions in the companies shows, that a clear separation into the three fields (Figure 2) is not performed or is not reasonable. This is because an uniquely failure effects the system-, the design- and the process-FMEA (see Figure 4).

Within this picture it becomes obvious that in the conventional FMEA forms (see Figure 1) the columns 2 (type of error) and 3 (impact of error) have to be transposed in the FMEA form as shown in Figure

FMEA-method	Component Process	Function Purpose	Failure-effect	Failure-type	Failure-cause
System-FMEA	Distributor	Distribution of electrical impulses	No ignition; Car stops	Breakdown of the impulse distribution	Shaft broken
Construct. FMEA	Distributor finger	force fit on camshaft	Breakdown of the impulse distribution	Shaft broken	Shrinkage cavity
Process-FMEA	Spray-molding of distributor finger	guarantee-uniform grain	Shaft broken	Shrinkage cavity	Pressure too low

Figure 4. Ambiguity of mistakes, for example a car ignition system [14]

4. However, this becomes obsolete by the new approaches proposed in this paper.

Many products are so complex that a correction in one field of an FMEA method can cause new mistakes in the same field or in other fields. In Figure 4 it is shown that every product entity has a failure potential in every FMEA-method. The failure cause at a system-FMEA becomes the failure type at a design-FMEA and the failure effect at a process-FMEA. This circumstance contains the danger that potential sources of errors can be overlooked during the design process. If it is detected for example in the design-FMEA that a shaft tears due to a shrinkage cavity (Figure 4) constructive changes will result from this like for example changing the shaft diameter or choosing another material for the shaft. Through this change the putative appearance probability of the mistake is lowered (however, not the source of errors) and with that also the risk priority number (RPZ) which is an indicator for the taking of measures. The mistake discussed once is either eliminated and does not occur anymore in later design-FMEA or is marked as being ignored.

Since a system-FMEA is carried out before a design-FMEA this new influence into the system and his effects is not considered anymore. Only a carried out process-FMEA would discover the actual source of error, for example an unsuitable die casting machine. Again the influence from this failure elimination is not considered anymore in the system- and the design-FMEA.

In many cases the logical sequence of all three FMEA methods is not carried out due to the time pressure so that sources of error remain undetected. Even if a systematical realization of all three FMEA methods is carried out psychological effects of the human being cause that failures which have been discussed before from another viewpoint are not seriously reassessed anymore. Through this low willingness of the human being the efficiency of the FMEA method is reduced.

Out of these reasons it is not reasonable to carry out a sepa-

ration into the individual FMEA methods. It is more reasonable to carry out all three methods simultaneously in order to use synergies of the group. Influences of changes of the design in one method to the point of interest in the other method become more recognizable. The integration of a component into an overall system is reasonable because its functional design as well as its production process were already considered as one unit by the developer. Thus also a FMEA method as a closed unit is reasonable. The comprehensive consideration of the product, its components and its mode of operation during the complete product development process allows comprehensive recognition of failures.

In spite of new approaches to counter inefficiency and ineffectiveness, as for example the matrix-FMEA from Kersten [14], the separation into three independent methods is still carried out. The methods are orientated at the different stages of the product development process like concept, draft, design and production stage. On the one hand the terms like system- and process-FMEA are misleading since they are already used in another context. On the other hand they contradict to the basic idea of simultaneous engineering (see [1]), because they are carried out as concluded, serial processes. However, if the separation into different independent methods should be maintained (see also G. Kerstens approach of a Matrix-FMEA, [14]) the system-FMEA should be renamed to concept-FMEA, the design-FMEA to structure-FMEA and the process-FMEA to production- or realization-FMEA.

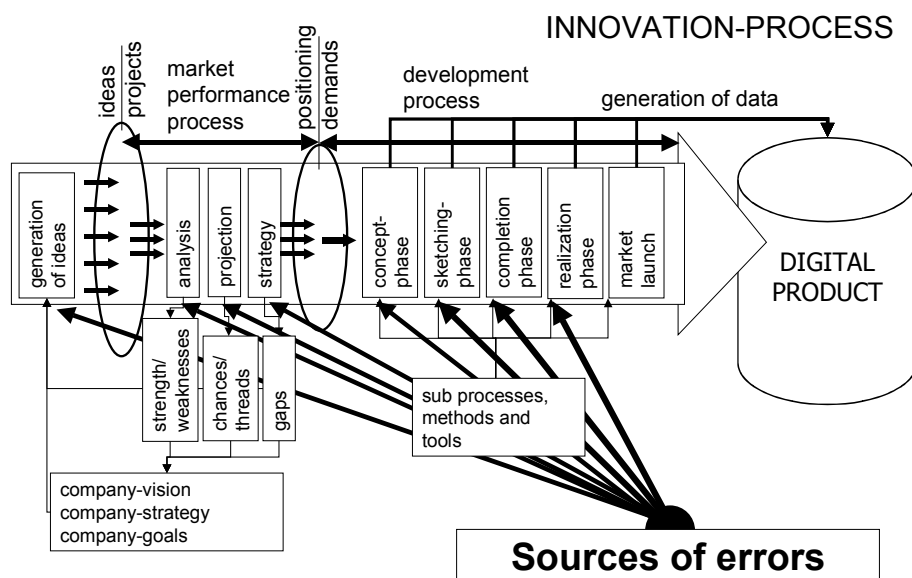

Figure 5. Each stage of the product development process contains sources of error

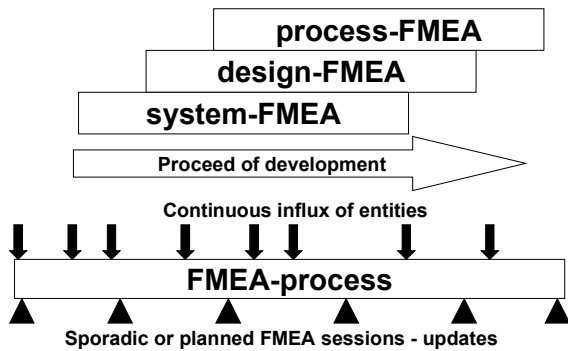

Figure 6. FMEA, separated in sub-processes or as a continuous process?

In general the early stages of the product development process and the stages during and after the market launch are not covered by a FMEA. The already mentioned early phases of the product development process (idea generation and market performance process) include many sources of errors that influence the success or failure (not only in the technical aspect) of a new product. In addition essential sources of error in the product development process are not considered as for example the process of data generation (see Figure 5).

Such possible additional sources of errors can be discovered with:

- Feasibility-FMEA (FMEA to detect possible errors within the objectives).
- Plausibility-FMEA (FMEA to detect sources of error within the demands [7]).
- Use-FMEA (generated from the use analysis [4]).
- User-FMEA (FMEA to analyze and detect possible errors of the "fallible" human being [5], [6]. Since the human being can not be objectively quantified also possible solutions are discussed where the "fallible" human being can be replaced by an automatization [6]).
- Function-FMEA (FMEA to analyze the functional performance - as up to now).
- Component-FMEA or module-FMEA (FMEA to analyze a component or a module on its importance).

This list can be made more detailed so that every stage in the product development process can be combined with a very specific FMEA. The mutual networking of all operation steps in the product development process shows that a stage-

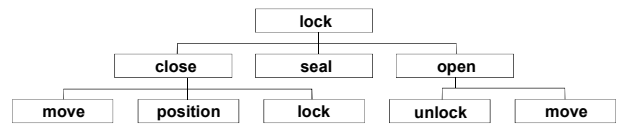

Figure 7. Example of a hierarchical functional structure of an autoclave door [8]

dependent distribution of the FMEA is not reasonable. Instead of this a continuous, accompanying FMEA has to be implemented that becomes more detailed with the increasing knowledge in the product development and thus in the product itself. With the proceeding design of a product and with the increasing knowledge also the danger of errors increases and thus also the need of their recognition and elimination. This implies a continuous FMEA (see Figure 6).

Such a continuity produces the best results if also the group of involved persons stays the same. In the practical usage of a FMEA it turns out that it is reasonable to have competence in manufacturing or quality control already in a concept-stage FMEA. This does not contradict to the demand that for specific questions specialists have to be consulted. An additional benefit consists for all team members in becoming acquainted with the product.

Under the aspect of construction (mentioned as weak point no. 2) and design (see Figure 3) the question how to structure column 1 of the FMEA-form and thus the entries becomes obsolete. First of all the

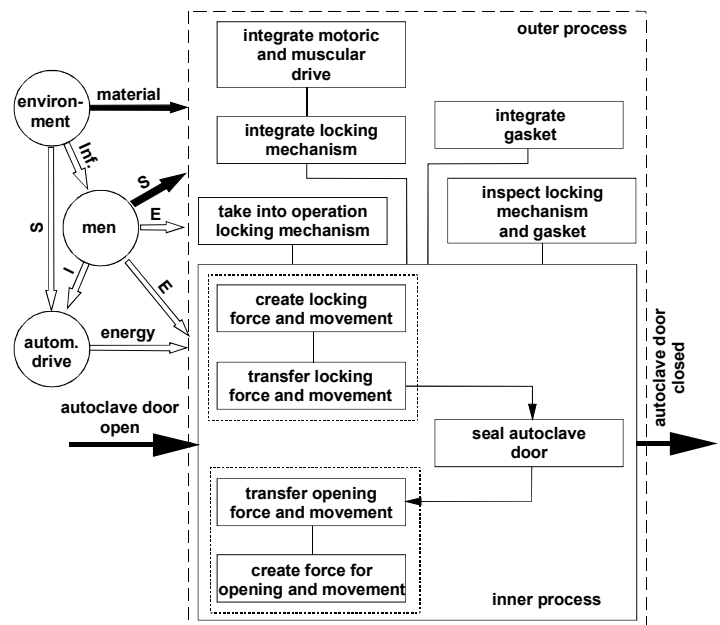

Figure 8. Example of a processual functional structure of an autoclave door, generated out of Figure 9 [8]

ETH Zürich	Failure Mode and Effect Analysis FMEA			
Idea Market analysis Cost planning Time scheduling Strategy	Impact of failure	Type of failure	Failure cause	Means of control
1	2	3	4	5

Figure 9. FMEA form with modified column 1, in particular for the stage of the generation of ideas and for determining the market performance profile

inner and outer functions that are obtained from the hierarchical (see Figure 7) or - even better - from the processual functional hierarchy (see Figure 8) have to be entered in this column. Second the fulfillment of the functions have to be challenged (see Figure 3). The modules will follow as well as their assembling and disassembling. Afterwards the components are discussed regarding their function, their manufacturing and the needed manufacturing process. (see Figure 9).

Since already in the first stages of Figure 5 sources of error can be detected the corresponding entities have to be entered in column 1 of Figure 9.

Referring to Figure 5 in all following stages also

ETH Zürich	Failure Mode and Effect Analysis FMEA			
Inner and outer functions Module Assembly Component Manufacturing process	Impact of failure	Type of failure	Failure cause	Means of control
1	2	3	4	5

Figure 10. FMEA form with modified column 1, in particular the development process

ETH Zürich	Failure Mode and Effect Analysis FMEA			
Storage Transport Mounting Initiation	Impact of failure	Type of failure	Failure cause	Means of control
1	2	3	4	5

Figure 11. FMEA form with modified column 1, in particular for the market launch

sources of error can be detected and thus the corresponding entities have to be entered in column 1 of the FMEA-form (see Figure 11 and Figure 12).

In a further step the human being in his incompleteness as users during the product life must be included into the FMEA. The user is a component of a system, he influences all processes, starting from the generation of ideas over the development and the usage till the end of the product life. He causes failures and errors in all stages which are not yet considered by any FMEA. With the integration of the available use analysis that covers all stages of a product's life [4] also possible sources of error during assembling, maintenance and repair are considered (see Figure 12).

ETH Zürich	Failure Mode and Effect Analysis FMEA			
Implementing Operation Controlling Maintenance Repair Recycling or liquidation	Impact of failure	Type of failure	Failure cause	Means of control
1	2	3	4	5

Figure 12. FMEA form with modified column 1, in particular for the usage phase up to the product disposal

No.	sub-function first order	men-product-relationship: needed activities	men-machine interface	affiliated requirement	required functions resp. possible carriers of function
1	detection (of the object)	nutcracker: seek ask for find	eye - object sense of touch - object	noticeable design recognizable design shiny color	color contrast grade of reflection
2	transporting/ placing (the object)	nutcracker: grasp, lift, carry put down slacken	hand - handle hand - object body eye - hand - handle	little weight, ergonomic handle, handy surfaces "crack protection" stable stand	lightweight construction handle - leverage corrugated surface platform
3	equipment (with a nut)	open nutcracker insert nut	hand - object hand - nut	easy to equip safely to equip	trough stop
4	locating (of the nut)	hold nut press against stop clamp nut move leverage	finger - nut hand - nut eye - finger - nut	easy to use sure hold of nut limit clamping force	trough clamping claw vise
5	produce (opening-)force	hit against anvil turn knob	hand - leverage fist - anvil hand/finger - knob	sure force insertion notice finger/hand-span	handle leverage
6	guide force/ amplify force	<i>inner function</i>	/.	force-amount [N] distance-amount [mm] limit force/distance	leverage spline screw
7	nut opens by: - pressure - effect of spline	<i>inner function</i>	/.	<i>selection of effective functionalities that can be cheaply realized</i>	thrust piece splines blade clamping screw
8	remove (result)	remove cracked nut remove nut and shell	finger - cracked nut hand - cracker nut eye - finger - cracked nut	easy to remove sure to remove	collecting pan, sack basin flap opening
9	cleaning	hold nutcracker shake out crack room clean crack room	hand - nutcracker finger/hand - cleaning device	easy to handle no unreachable corners easy to clean surface	"room design" shape of surface surface roughness

Figure 13. Use analysis of a nutcracker (from: ETHZ)

The following departments should designate at least one participant as a continuous FMEA team member:

- Project management
- Construction and calculation
- Manufacturing preparation
- Manufacturing
- Quality control
- Purchase
- Sales department
- Customer support (maintenance and repair)

As an example an electrical plug-in contact is given that was reviewed concerning its electrical and mechanical load. It was discussed in a FMEA without including the influence of the human being. Including the human being into the FMEA shows that an oxidation of the contacts can arise from perspiration

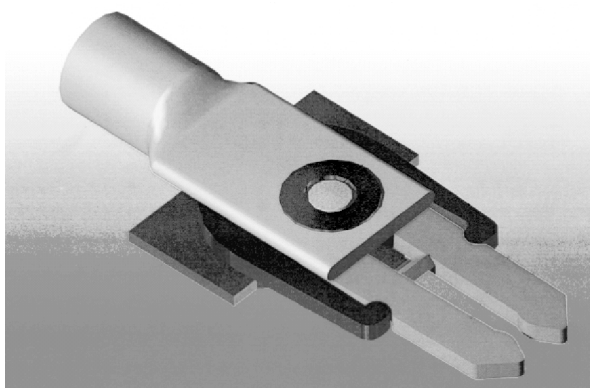

Figure 14. Small product: plug-in contact (from: ABB)

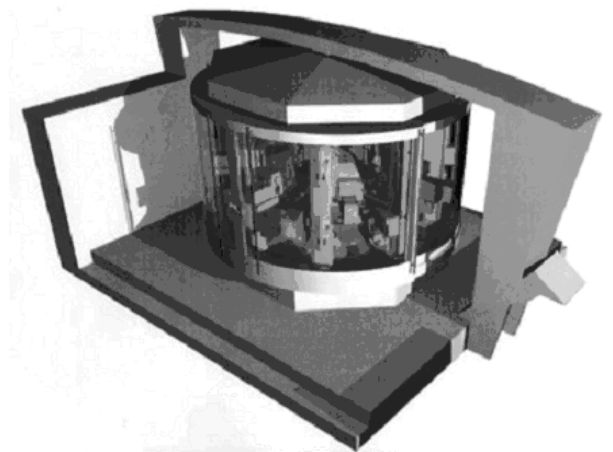

Figure 15. Large product: machine tool (from: Breiing, Mikron)

if the contacts are touched with bare hands. Since a corresponding note in the assembly manual was considered as insufficient (risk priority number still too high) a change in the manufacturing process of the contact was decided. The contacts are now provided with a wax layer as a protection against oxidation. The layer can only be mechanically removed by the other contact. The regulation to carry gloves during the assembly would not be a sufficient protection against oxidation.

The example shows how new mistakes are detected by integrating the human being and his usage of a product into a FMEA and what effect results from this onto the production process. In order to register these potential sources of error systematically the FMEA is expanded by another aspect: the integration of the use analysis. The entities can now be taken from the tabular recording of the man-machine interfaces.

4. PROCEDURE

The localization of risks concerning the lifetime of a product, starting from the first idea over the design up to the usage of a product, is in principle always the same procedure, regardless of the products size.

No.	Faculty / Customer	Name, First name, Company
1		
2		
3		
4		
5		
6		
7		
8		
9		

Figure 16. Visualization of the team members in a form

The principle and the procedure is identical for a plug-in contact (Figure 14) or a machine tool (Figure 15).

The procedure is as follows:

- Description of the project
- Nomination of the FMEA moderator.
The nomination is done in accordance with the responsible project manager.
- Formation of a FMEA team.
The formation of the team (see Figure 16) is done by the project manager in accordance with the FMEA moderator.
- Structuring of functions
The basis of a FMEA is the function analysis of the investigated product. This implicates the specification of functional modules or sub-modules as shown in Figure 17.

Instead of a hierarchical functional diagram also a process orientated diagram can be used.

- Filling out the FMEA form

Column 1:

As mentioned before the column 1 of the conventional FMEA form is modified as shown in Figure 9 to Figure 12.

Possible errors in the planning stage

- The idea of a new product can not be realized due to physical, chemical, biological, ethical, legal or cultural constraints or restrictions.

- The product idea is already realized by competitors.
- The product idea is already protected by the competitors by patents, petty patents and/or design patents.
- There is no market potential and/or no market gap available.
- The time is not ripe.
- No foe image available or not relevant enough (for military development).
- Rare resources.
- No sustainable environment.

Possible errors in the development process

Inner functions out of a function analysis (hierarchical and/or processual functional structure).

Outer functions out of a use analysis.

Assembly out of the product structure.

Assembly/Disassembly:

- Assembly/disassembly operation
- Assembly/disassembly regulations
- Utilities (e.g. oil for the removal of bearings)
- Assembly/disassembly devices
- Control and/or measuring devices (e.g. torque spanner)
- Additional means (z. B. hoisting devices)

Components out of the product structure and/or parts list.

Manufacturing:

- Manufacturing processes (e.g. lapping)
- Manufacturing operations (for manual manufacturing, e.g. deburring)

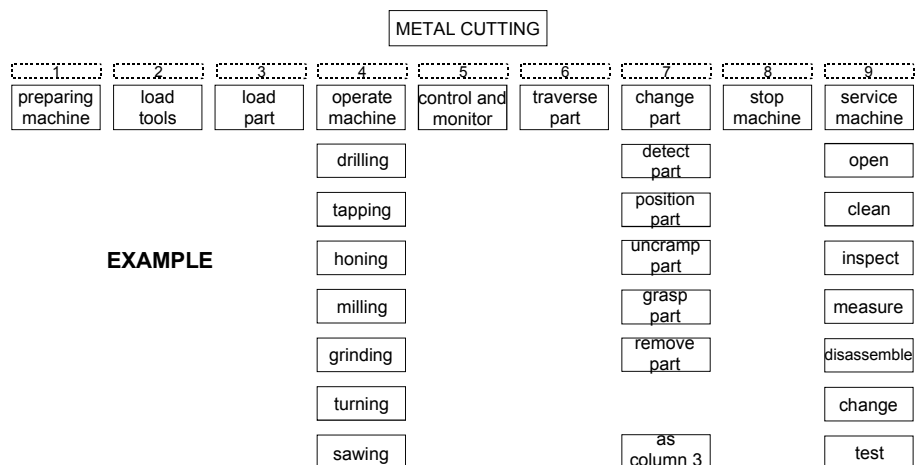

Figure 17. Hierarchical functional diagram of the machine tool from Figure 15 (from: Breiing, Mikron)

- Manufacturing regulations
- Manufacturing means and devices (e.g. drilling patterns)
- Auxiliary means for manufacturing (e.g. coolant)
- Control and measuring devices (e.g.. calipers)

Moreover each part and every assembly and every product needs a documentation mentioned in the following list:

Possible errors within the technical documentation:

Check the:

- Manufacturing documents (drawings and lists)
- Documents for assembling/disassembling (e.g. instruction sheets)
- Calculation documents like
 - Load assumptions
 - Verification of strength
 - Verification of deformation
 - Verification of stability (e.g. buckling, bending, stability)
- Balances like
 - Balance of performance
 - Balance of weight
 - Position of the centers of gravity
 - Balance of the moments of inertia
 - Balance of temperature
 - Balance of coolant
- Documents like
 - Instruction sheets
 - Instructions for maintenance and service
 - Spare part catalogue

In practice very often checklists are used for complex products or technical systems in order to perform a systematical test. The following checklist is an example how to check the manufacturing documentation, i.e. drawings and lists for the manufacturing of the product and/or the technical systems as well as for manufacturing test devices, assembly gadgets and measuring and test equipment.

Checklist to verify the manufacturing documents

- Drawings (observe guiding principles of the company and check for apparentness)
- Accuracy of the nomenclature
- Accuracy of the used abbreviations
- Number of the drawing
- Number of pages
- Classification in the drawing of the assembly = product structure (if available)
- Classification to the parts list

- Scale of the drawing (main scale and additional scales)
 - Completeness of the dimensioning
 - Completeness of the specified positions (i.e. comparison with the parts list)
 - Quality of the drawing (readability, positioning of the views, detailed views and cut views, line types and line diameter [standardized drawing rules])
 - Entry of the used material
 - Entry of the finish quality and surface processing
 - Entry of the finish / surface protection (Attention: fits in drill holes and/or openings)
 - Entry of needed surface protection before the galvanic treatment. Attention if only one status of the part is needed the final state (e.g. after the galvanic treatment) has to be defined, if necessary the dimension before the treatment can be added in brackets.
 - Entry of tolerances (measurement, angle, shape, and position [only if needed, e.g. in cost oriented projects])
 - Entry of overall tolerances (size and angle)
 - Entry of overall radius
 - Details for the manufacturing process
 - heat treatments
 - hardness, if necessary hardening procedure
 - welding techniques
 - bonding techniques
 - painting sequences and procedure of painting
 - number, kind and orientation of layers (composites, laminates, sand-wiches, plywood)
 - Details for assembly
 - short assembly instruction for an assembly on the relevant drawing (e.g. „Pos. mm and Pos. nn have to be drilled separately“)
 - Cross reference to other documents of a specific part (calculations, diagrams [measurement results], instructions, test results etc.)
 - Symbol for the way of illustration (e.g. First Angle Projection)
 - Note if a non-metric measurement has to be used
 - Remarks for copyrights
- Parts list (observe company's guidelines and check for evidence):
- Transparent correlation between parts list and assembly drawing

- Accuracy of the parts list name
- Accuracy of the parts list number
- Number of pages
- Correct entries in rows and columns
 - Position (analog positioning for assemblies, assembly drawings)
 - Description (observe order given by the instructions), description also on standard parts
 - Quantity for an assembly and/or a product
 - Drawing numbers for all detail drawings
 - if necessary: additional drawings, e.g. perspective model view
 - if necessary: article code
 - if necessary: standardized naming
 - if necessary: material
 - if necessary: suppliers
 - if necessary: weight of parts
- Copyrights

Drawings and lists in general

- Company's name and logo
- Status of drawing
 - Replaced by ...
 - Replacement for ...
 - Initials from the person that modified the drawing
 - if necessary: date of change
 - Hint on messages for modification
- Originator, date of origin
- Verifiers (Number of verifiers in accordance with the guidelines)
- Date of verification

Possible errors during the market launch

Storage

- Activities
- Apparatuses (e.g. bearing block)
- Racks, halls, stacks (e.g. storage rooms with air condition)

Transport

- Activities
- Apparatuses (e.g. lifting gear)
- Means of transportation (e.g. overhead crane)

Mounting

- Activities
- Mounting regulations and instructions
- Apparatuses (e.g. lifting gear)
- Measuring and test equipment (e.g. theodolite)

Initial operation:

- Activities and tests in accordance with

- Instruction manual Chapter „Initial setup“)
- Checklist
- User's handbook
- Maintenance instruction

Possible errors in the use stage and in decommissioning

Initial operation:

Activities in accordance with:

- Instruction manual (Chapter „Initial setup“)
- Checklist
- Maintenance history
- Document

Operating:

Activities in accordance with

- Instruction manual
- User's handbook

Maintenance:

Activities and test in accordance with

- Instruction manual
- User's handbook
- Service documentation
- Maintenance history (e.g. exhaust gas document of a motor vehicle)

Service:

Activities and test in accordance with

- Instruction manual
- User's handbook
- Service manual
- Spare part catalogue
- Logistics documents (e.g. global workshop catalogue)

Columns 2 - 4:

These columns require:

1. An analysis of potential failures, for example retrieved from the service department.
2. A failure recognition (see paragraph 3 from chapter 2).

Column 5:

Here the status of currently used measures for the prevention of failures and the test procedures is entered. These entries are used to reduce the failure causes from column 4 and to detect possible sources of error.

Columns 6 - 9:

These columns are used to calculate the risk priority number RPZ.

$$RPZ = A \cdot B \cdot E \quad (1)$$

with:

A = Probability of a failure incidence

Unlikely	1
Very low	2
Low	3
Medium	4
High	5
Very high	6

B = Consequences for the customer

Consequences not noticeable	1
Inconsiderable inconvenience for the customer	2
Small inconveniences for the customer	3
Inconvenience for the customer	4
Irritation of the customer	5
Possible loss of the customer	6

E = Probability of a failure detection

Very high	1
High	2
Medium	3
Low	4
Very low	5
Unlikely	6

Instead of the absolute measure of 1 - 6 also a range of values from 1 - 10 can be chosen. This is only reasonable if detailed knowledge is available, for example within a FMEA in the end of the product development process.

A verbal description of the RPZ is:

Unacceptable high	216 resp. 1000
Medium	64 resp. 216
Low	1 resp. 1

In practice the failure values RPZ that are lower than 27 resp. 125 are not used to remove a failure (for profitability reasons).

Column 10:

In this column the actions for trouble shooting are entered.

Columns 11 - 15:

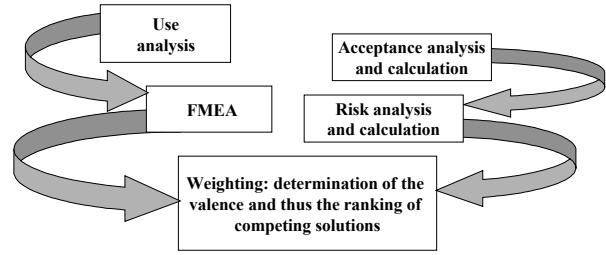

Figure 19. Context between acceptance, risk and weighting

Supposing that the recommended actions from column 10 are realized the actions are described in columns 12 and the RPZ is calculated again. The measure is accepted if the RPZ is below the level described in the above (27 resp. 125).

5. EXTENSION OF THE FMEA BY INTEGRATING A COST TREATMENT

In this case the FMEA form obtains an additional column "K" for the costs and all ordinal numbers of the following columns are increased by 1 (see Figure 18).

The values to be entered in this column "K" have the following meaning:

No or negligible raise of costs	1
Little additional costs	2
Medium additional costs	3
High additional costs	4
Extreme high additional costs	5
Non budgeted costs	6

In this case the risk priority number is calculated by:

$$RPZ = A \cdot B \cdot E \cdot K \quad (2)$$

6. FURTHER USAGE OF FMEA RESULTS

Within the concept phase and the sketching phase (see figure 2) several competing solutions or alternatives are available. In order to find out the best solu-

Fehler-Möglichkeiten und Einfluss-Analyse (Failure Mode and Effect Analysis - FMEA)										Name of function, working principle and assembly: Ident-No.:						
Generating department										Generated by: Date:						
Failure location Ident-No.	Type of failure	Impact of failure	Cause of failure	Present status						Remedial action	Improved status					
				Means of control	A	B	E	K	RPZ		Realized actions	A	B	E	K	RPZ
1	2	3	4	5	6	7	8	9	10	11	12	13	14	15	16	17

Figure 18. FMEA form with additional column K

tion a ranking procedure is carried out. If the criterion "risk" is already part of this ranking procedure it is reasonable to use the sum of the RPZ of each individual solution.

The context between acceptance, risk and weighting is shown in Figure 19

7. SUMMARY

Since every product entity can have a failure potential in every FMEA sub-process a separation into different FMEA methods is not reasonable. Instead of this a realization is proposed as a continuous course of events over all stages of a product development process. All involved persons add inputs at any time and also can use the complete FMEA documentation. These persons must be involved in the FMEA during the whole process of development, a replacement is not reasonable.

Furthermore an enlargement of the FMEA is proposed by the aspect of the human being. Preferably the results of the use analysis can be used to recognize possible sources of error which arise from the use of a product by the human being.

The FMEA is used not only for the error recognition, elimination and prevention. The results should influence the entire evaluation complex because the knowledge of the product sensitivity are a criteria for an acceptance analysis, a risk analysis or they can be used for the decision among competing product variants.

8. FUTURE WORK

Future work will evaluate the proposed changes in the FMEA methodic at practical examples together with the industry. In particular it will be examined what changes will result from integrating the human being into the FMEA method.

After a successful realization of this evaluation stage the results should be transferred into a new or existing FMEA software [2], [11] so that a fast and simple realization of the FMEA becomes possible in practice. In addition it would be very useful to integrate the results from the above in future applications like [12], [16].

REFERENCES

[1] Abeln, O., (1995), CAD-Referenz-modell; Verlag B. G. Teubner, Stuttgart (D)

[2] APIS GmbH, (1992-1998), IQ-FMEA V3.5; The Knowledge Base; Wörth/Donau (D)

[3] Berens, N., (1989), Anwendung der FMEA in Entwicklung und Produktion; Verlag Moderne Industrie, Landsberg (D)

[4] Breiing, A., (2000), Vertiefungs-vorlesung Produkte-Design; ETH Zürich, IMES, Zürich (CH)

[5] Breiing, A., (2000), The Evaluators Influence on the Results of Evaluation, First International Workshop on Multicriteria Evaluation, Neukirchen (D)

[6] Breiing, A., Who evaluate the Evaluators? International Conference on Computer Integrated Manufacturing, Zakopane (PL) 2001

[7] Breiing, A., Knosala, R., Bewerten technischer Systeme; Springer-Verlag (D), Berlin Heidelberg New York 1997

[8] Breiing, A., Flemming, M., Theorie und Methoden des Konstruierens; Springer-Verlag (D), Berlin Heidelberg New York 1993

[9] Conrad, P., Hedderich, P. E., Navy Proactive Maintenance (USA) 2000

[10] DIN 25448, Ausfalleffekt-Analyse; Beuth-Vertrieb GmbH, Berlin (D) 1978

[11] Frei, S., Erstellung eines FMEA-Software-Prototypen mit integrierter Visualisierung und Datenbankkopplung; Diplomarbeit, ETH Zürich (CH) 2000

[11] Good, J., Blandford, A., Incorporating a user-focused failure modes and effects analysis-like technique into the design of safety critical systems; London (UK), 2000

[12] Kepner, Tregoe, Entscheidungen vorbereiten und richtig treffen; Verlag Moderne Industrie, Landsberg (D) 1988

[13] Kersten, G., Matrix-FMEA, Grund-seminar für System-, Konstruktions-und Prozeß-FMEA; Vaihingen/Enz (D) 1998/2000

[14] MIL 1629A, Procedures for Performing a failure Mode, Effects and Criticality Analysis (FMECA); Military Standard, (USA) 1980

[15] Moore, C., Failure Modes and Effects Analyses (FMEA) and Critical Items List (CIL) for the ECS Project; EOSDIS Core System Project; Hughes Applied Information Systems Upper Marlboro, Maryland (USA) 1996

[17] Mashhour, T., (1997), Akquisition und Verarbeitung von Wissen zur Entscheidungsunterstützung im Konstruktions-prozeß unter Einsatz von Neuronalen Netzen; Shaker Verlag GmbH, Aachen (D)

[18] Schubert, M., FMEA – Fehler-möglichkeits-und Einflußanalyse; Deutsche Gesellschaft für Qualität e. V., Frankfurt am Main (D) 1993