

## From Verbal Models to Mathematical Models – A Didactical Concept not just in Metrology

Karl H. Ruhm

Institute of Machine Tools and Manufacturing (IWF), Swiss Federal Institute of Technology (ETH)

**Abstract:** The application of mathematical models in everyday Metrology does not seem to be an urgent mission. And Mathematics, though a ubiquitous discipline, does not play a major role either. The following sections propose that the prevalent educational concept in Metrology should for once change sides and should use the top-down approach of interdisciplinary mathematical model structures. The current educational concept regarding all these bottom-up approaches serves fields of diverse and limited interests only and is not able to attract the Metrology Community as a whole.

This survey illustrates how empirical and analytical approaches use appropriate mathematical models based on Signal and System Theory. Only a few basic concepts are necessary to fit interdisciplinary measurement requirements.

Such a holistic procedure is rewarding; pursuing structured relations and processing observed data are universally valid activities. They simplify and foster common understanding of structural issues in Metrology.

**Keywords:** metrology, mathematical model, signal and system theory, top-down strategy

### 1. INTRODUCTION

The *educational concept in Metrology* has always been [7] and still is [2] a topic in different areas and on different levels. With few exceptions, the diverse proposals prove to be instrumentation and field oriented, or rather technology and application minded. Of course, such advancements are not harmful at all, but we only see one side of the coin.

On the other hand, we appreciate the deserving contributions from the Philosophy of Science [9, 10], which discuss, what the terms *inquiry, investigation, evaluation, examination, surveying, collection, estimation, mapping, determination, acquisition, observation, test*, and of course *measurement*, presumable could stand for. Unfortunately, too many denominational concepts are too divergent to be useful for people from both, the scientific and the technological background: We only see the other side of the coin.

There are several proposals imbedding broad epistemological ideas, but they appear to be rather punctual amendments to classical habits [4, 6, 7, 8]. We are still waiting for an overall, culminating outcome.

The following top-down concept focuses intentionally and primarily on a *set of quantities of interest* and on the *relations* between them in order “to de-

scribe the world”. Surprisingly, or may be not, this is all very simple! There is an explicit mathematical reason for such an approach: All *mathematical models*, which describe *processes* by means of *System Theory*, are only *logical expressions* and/or *mathematical functions*. They *relate*, analytically and/or numerically, models of quantities, nothing else. We just have to hold strongly to the term quantity with the hierarchically ordered sub-terms especially in Metrology, namely: *quantity of interest, quantity intended to be measured, quantity actually measured, quantity indirectly measured, and immeasurable quantity*.

Using this approach, we have two domains, the domain of *real quantities* of *real processes* on one hand and on the other hand the domain of the mathematical models, which *describe* these quantities as *virtual quantities*. Both domains provide their own terminology, which should not be identical if we want to avoid misinterpretations. There is a correspondence: The term *quantity* and the terms *property* and *behaviour* concerning the process of interest comply with the term *variable* and the terms *structure, parameter* and *solution* from the mathematical point of view.

The mathematical description of interrelations serves as an obvious entrance to *Measurement Science*. Normally, we tend to forget that any measurement result bases on practical objectives *and* on theoretical principles. The best evidence for this is the important issue of measurement errors and uncertainties. It is *defined* theoretically by mathematical models first, *and* then *determined* by calibration and inference in practice.

We must all admit that imprecise terminology and uncoordinated standards across diverse fields in Metrology stimulate undesired ambiguity. This could be reduced in a top-down manner by using Signal and System Theory accompanied by Stochastics and Statistics. The following reduced terminology is still controversial, but consistent at least. We will try to restrict ourselves to few terms to the point and to avoid vogue and vague terms in the verbal descriptions. Here we will consider quantitative measurement with analytical and numerical relations only. We follow the (unfamiliar) distinction between the domain of processes and procedures (*concrete reality*) and the domain of mental ideas, concepts and models (*virtual reality*) [11]: This is extremely useful.

The following sections start with general remarks concerning mathematical modelling in a top-down approach and from the point of view of Signal and System Theory. In the second half, we offer applications in Metrology, assisted by graphical structures. We highlight the importance of modelling in Metrology in Section 2. Section 3 addresses the description of processes in general. Section 4 describes modelling on selected levels of measurement demands in a rather tutorial manner. Section 5 is special, insofar as an *Axiom of Metrology* is postulated, from which basic measurement models are derived. Mathematical models of quantities are often neglected. We treat some aspects in Section 7. Since Metrology is normally linked to other important fields, section 8 provides a summary of co-processes in the surroundings of measurement processes. This leads to an impressive overall scheme, which exhibits the concept of a control loop.

## 2. METROLOGY, MODELS AND EDUCATION

In every area of expertise we keep dealing with measurement challenges in an ad-hoc way and do so successfully, applying approved technology and dedicated instrumentation. The results appear trustworthy, especially as they are often sanctioned by some computational treatment. And the general opinion is: Measurement procedures are easy going. We acknowledge the enormous gross national product of industrialised countries in this area: Metrology, an unwritten success story.

However, success makes lazy lads. But why should we bother? Answer: There is an ever-increasing demand as to the *complexity of measurement tasks*. We generally need a common understanding of what measurement tools look like or should look like, and how measurement procedures run or should run, and this independent of the fields of application, sort of interdisciplinary. That is where models come in. Nowadays, most measurement solutions are still extremely field oriented, so are terminology and education.

*Metrology is Measurement Science and Technology* [1]. *Measurement Technology* is covered very well by literature, by application notes and fairs of producing companies and by myriads of conferences and seminars. All the same, we always hear the main tenor: "Please, crack my burning problem. Now! But no Theory, no Math!".

Measurement *Science* however is a stepchild. No globalisation in Measurement Science can be observed so far, although we urgently need general education in this respect. Textbooks are missing. Descriptions of sensors, recipes for instruments and suggestions for good practice definitely are not significant enough.

Ludwik Finkelstein has recently reported on this situation [2]. One of his alarming statements is that *general education in Metrology* is either totally lacking at university level, or, even worse, that rudimental

remains keep declining in favour of seemingly more attractive and promising subjects.

Is there any vision of a general concept concerning Education in Measurement Science at all? Is there a crucial centre point? Yes, there is: The comprehensive mathematical model of the whole information generating and supplying process in Metrology. Then, is Measurement Science, thus declared as Information Acquisition and Processing Theory, considered as a basic subject like Mathematics, Physics, Chemistry, System Theory, Probability Theory, Control Theory, Information Theory and the like? If "Yes", then all natural science and engineering fields should provide one, and only one, commonly shared curricular activity, called «Measurement Science», with a *top-down strategy*, interdisciplinary in concept, across all faculties. Hence, in addition on such a basis, all the numerous and different branches of studies would be able to design, pursue, offer and teach individually their very specific necessities and solutions concerning Metrology in a *bottom-up strategy*.

Apart from this fundamental organisational concept, what would we like to see in an overall curriculum regarding the common content in Measurement Science? Not too much, actually. Let us look at some keywords, which all can be discussed systematically based on appropriate mathematical models:

- There are statements, what Measurement Science tasks do and do not look like, especially *acquisition* and *description*, and *not, explanation*.
- There are specific terms concerning *data, information* and *knowledge* and their (meta-physical) definitions.
- There are well-defined, issue-related terms as for example concrete and virtual, causal and acausal, objective and subjective, qualitative and quantitative, dynamic and non-dynamic, deterministic and probabilistic, observable and unobservable, ideal nonideal and their (meta-physical) definitions.
- There are the terms *properties* concerning the quantities on the one hand, *properties*, and *behaviour* concerning the processes on the other hand.
- There are optimising strategies for *spatial sensing configurations*. They consider quality and expense of sensors, which acquire important and unimportant quantities.
- There are strategies regarding traces back to defined *standard quantities*.
- There are two principal types of processes involved, the *processes observed* (process domain) and the *processes observing* (instrumental process domain). There are demands and rules concerning the *interrelations* between the two. The realised physical fusion of both types is called *process under measurement*.
- There are objectives concerning the excitation of processes observed (stimulation, activation, actuation, animation, guidance, driving, conducting, steering, control) in order to gain observable effects, powerful enough to be measurable by measurement processes.

- There are *two viewing directions* to describe and analyse a *measurement path*:

1. The *feed-forward viewing direction* from the quantities actually measured in the direction to the resulting quantities (cause to effect path, forward path, description path); *Stochastics* applies for random contributions in participating quantities.

2. The *feed-back viewing direction* (effect to cause path, retrospective path, return path, inference path, analysis path) from the erroneous resulting quantities to the intended purpose of the measurement procedure, back to the quantities actually measured; *Statistics* applies for random contributions in measurement results.

- There are two *performance domains*:

1. The vision of the unreal, *ideal, error-free situation* in measurement, represented by a *nominal model of the process under measurement*; it is never realisable.

2. The every-day confrontation with the real, *non-ideal, error prone process under measurement*, represented by a model, showing all error sources; it is always to be accepted.

The discrepancies between ideal and nonideal situations lead to the definition of *deterministic and random errors* and to *uncertainties* in measurement processes and in resulting quantities as well.

- There are two different concepts concerning quality in metrology: *measurement error* and *measurement uncertainty*. It is the objective of the *quality assurance process*, to unite them in the resulting quantities.

- As a summary, there is a common pivotal point in Measurement Science: Measurement is always *Model-Based Measurement* with the two types of protagonists, *quantity* and *process*.

Now, another statement, not to be underestimated: These seemingly simple issues, said to represent fundamental concepts of Metrology, have consequences concerning comprehension, design, implementation, operation, qualification and communication in most Sciences and Technologies as well. All these keywords root without exceptions in basic propaedeutic fields like Mathematics, Signal and System Theory, and Stochastics and Statistics.

### 3. MATHEMATICAL MODEL – DESCRIPTION OF A PROCESS

Where is modelling to be positioned? Of course, Philosophy of Science, on top of a generally accepted hierarchy, has a much broader setting of a task with its holistic approach; but vision, concept and procedure are alike. This is true for Ontology on a lower level too, which deals with the meaning of reality, with the nature of being and with the existence of entities and their interrelations. Models of reality of any type are basic tools, independent of how they are designed and of what they look like.

What is a process? The cosmos, a stock exchange, a medical diagnosis instrument, a human being, a vehicle, a production machine, a population of a town, a sensor and so on. How do we describe such a process, its properties and its behaviour?

For a start we do it *verbally*. The description is more or less appropriate, more or less elaborate, more or less detailed, more or less accurate. The result is a model already, a qualitative model. It is useful, since we can discuss it and since it is suitable as the base of some decisions. If we were careful, it has become a quantitative model by now. Any quantitative model starts on such a preliminary qualitative model.

Now, how does the verbal model of the process come up? We select and identify the group of quantities of interest, which influence the process: input quantities. And we select and identify the group of quantities of interest, which result from process procedures and process responses: output quantities. We describe them individually and jointly in the group and get qualitative and / or quantitative models of the quantities, called signals.

Qualitative and quantitative relations between these groups of input and output signals describe properties and behaviour of the process. The *cause-and-effect principle* dictates this approach. Right now we realise that a process is described by signals. By the way, the identification of a process works like this: We collect data from the groups of input and output quantities by measurement and derive the structure and parameters of the model of the process from the information within these data: model building by data or by calibration.

*Structures* and *parameters* in mathematical equations represent *properties* of the model. We assign them to the quantities and processes of interest. These structures and parameters are always *hypotheses* and *estimates* respectively, prone to errors and uncertainties [15].

Signal Theory and System Theory are only two tools among others to handle models. But they are by far the most important ones for a description of quantities (signals) and of processes (systems) [16; 17].

In the 1950s the famous *State Space Description* was introduced [18]. It is a tool of Signal and System Theory, which systemises the handling of sets of equations by a single mathematical structure, describing small and large dynamic systems in a most efficient and elegant way, almost for anybody. This enabled the realisation of user-friendly, descriptive and powerful simulation software.

Models in different fields seem different at first glance, and they really are for the individual applications. However, upon closer examination we recognise the common roots and tools, first and foremost Formal Logic, Mathematics, Stochastics and Statistics.

Models are used everywhere. They *describe* properties and behaviour of processes in time and space. Processes may concern natural and artificial artefacts; they may concern human or non-human matter. There is no principle and structural difference in creating and

operating models in all these different fields of application.

There are real, physical models, physically built and operated by human beings, and there are virtual, abstract models, designed and started by our mental visions. Most models we use in our daily life are *qualitative* in character and are often delivered verbally. In many sciences, we employ quantitative models in order to get numerical answers about processes. The answers are *descriptions*, they do not give *explanations*. Explanations are searched afterwards by human beings or by programs using so called artificial intelligence and expert knowledge. Based on descriptions and explanations we take decisions.

Mathematical models do not only describe properties and behaviour, but also try to *predict* to a certain extent. The temporal and spatial horizon of prediction depends strongly on the *correctness of the model* on the one hand and on the exactness of the *initial and boundary conditions* on the other hand, when using the model in a simulator or in an observer. So, prediction is not always possible.

Models are not directly comparable with the processes they describe. They are on different levels, in different domains [11].

#### 4. MATHEMATICAL MODELS IN METROLOGY

##### 4.1. Definition and Separation of Quantities to be Measured

Generally but qualitatively speaking, the primary goal of any measurement procedure is acquisition, processing, storing and presentation of information by a measurement process, with *acquisition of quantities* of different types as the essential one. Mathematically speaking, the resulting data of a measurement procedure appear as different types, depending on the types of the measured quantities (nominal, ordinal, interval, ratio and so on). We get logic expressions or numerical values, "0" and "1" in the simplest case, and/or we get time and space series of numerical values, describable by discrete and/or continuous functions of any type. So, first of all, we deal with quantities and their representations (models).

As soon as we go more and more into detail of a qualitative model, we admit that we should select from the huge bulk of participating *quantities* all *quantities of interest*, and there may be many. Thereafter we search for qualitative mutual relations between these quantities; it is seldom an easy job. This leads to a separation and grouping of the quantities of interest into *independent* (input) quantities, *dependent* (output) quantities and *intermediate* (inner) quantities.

At this vital point Signal and System Theory enter with mathematical models of the quantities and of the processes. However, we had not defined what we want to understand under the term *process* here: A process is a selected part of *reality*, may it be natural and/or man-made [11]. For such a process, we have defined some of its quantities already, since quantities are inherent entities of processes. Now, we want to have

some sort of a model of this process. System Theory says that one important model type of a process is the *mathematical model* and that it (just) consists of the mathematical formulation of the relationship between all formerly selected quantities, defined as important. So, a mathematical model of a process does *not* intend to describe any physical or other *arrangements* and *appearances* of a real process, it only describes dependencies of selected quantities. The same is true for graphical representations of the mathematical models, for the *signal effect diagrams*. Again, they show effects and dependencies and no physical situations as piping diagrams, wiring diagrams, layout diagrams, and site diagrams usually do. This may seem unusual for hardware-oriented people. That is why real processes and their virtual models belong to different domains [11]. Nevertheless, these relations between quantity models have to reflect the reality as closely as possible and we have to verify that.

These seemingly trivial remarks about the handling of quantities are not trivial at all. We cannot start right from first principles. Let us remember the *Ohm law* or the *ideal gas law*. Which of the involved quantities are input, output or intermediate quantities? There are different answers, or, there are different models, for the very same process depending on the intended objectives. Therefore, a proper examination of all quantities is a stringent condition.

Assuming that we already found dependencies between the quantities of interest, we symbolise them graphically in a simple way in the signal effect diagram.

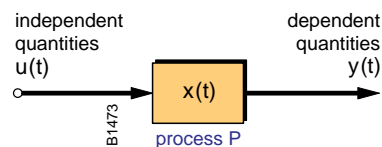

We only see the group (set, vector) of *independent quantities* (input quantities)  $\mathbf{u}(t)$  and the group (set, vector) of *dependent quantities* (output quantities)  $\mathbf{y}(t)$ . They are symbolised by the bold lines with direction arrows. The group (set, vector) of *intermediate quantities* (inner quantities)  $\mathbf{x}(t)$  disappeared in a block together with the mathematical relations between the quantities for now. Everything hidden in this block describes the process. The graph stands for the mathematical model of the process. The advantage of this approach: We are able to discuss to a large extent the situation around the process already without having detailed quantitative information. Later, further information may improve the model stepwise and recursively. At least some provisional mathematical expressions concerning the time-variable quantities are possible:  $\mathbf{g}(\mathbf{u}(t); \mathbf{x}(t); \mathbf{y}(t); t) = \mathbf{0}$  or  $\mathbf{y}(t) = \mathbf{f}(\mathbf{u}(t); \mathbf{x}(t); t)$ , called *model equations* already.

##### 4.2. Properties and Behaviour of a Model

We describe dynamical processes mathematically by *equations* and *differential equations*. They include

the process quantities as variables. How do we find back to the real process and to the real quantities in order to describe them? In this case, Signal and System Theory aim at two essential terms: *property* and *behaviour*.

Structures and parameters  $p(t)$  of all equations involved are assigned to properties of the process. Some of these properties are of purely artificial nature (observable, of  $n^{\text{th}}$  order, of minimal realisation, stable, critically damped, linear and so on). Some have distinct numerical values, often accompanied by physical units (gain value, stiffness value, damping value, thermal conductivity value, molar gas value, elasticity value and so on). Of course, there are other types of properties of processes around, which are part of other than mathematical models (large, sympathetic, durable, efficient, tasty, dangerous and so on).

If all input quantities of a dynamical and stable process are constant concerning time and space, then we say that the process is in a *steady state condition*. All derivatives within the set of equations equal zero. In this case, we are not able to detect and speak of any *temporal or spatial behaviour*. However, as soon as just one of the input quantities  $u(t)$  changes, the process will respond. We detect changes in one or the other of the output quantities  $y(t)$ . In practice, the process always behaves according to two causes, to its properties *and* to the amount of stimulation at the input. To make such responses comparable and describable, standardised excitation functions at the input are used during measurement and calibration, like impulse functions, step functions, harmonic functions, random functions and so on.

We get this behaviour either by experiment or analytically by solving the set of model equations with respect to the output quantities of interest. Solving linear ordinary differential equations (ODE) we get two solutions, the *homogenous solution* for the *eigen-behaviour* without any influence of input quantities and additionally the *particular solution* for the *behaviour*, due to the influence of input quantities only. The sum of both solutions describes the *overall-behaviour* as we have learnt in Analysis.

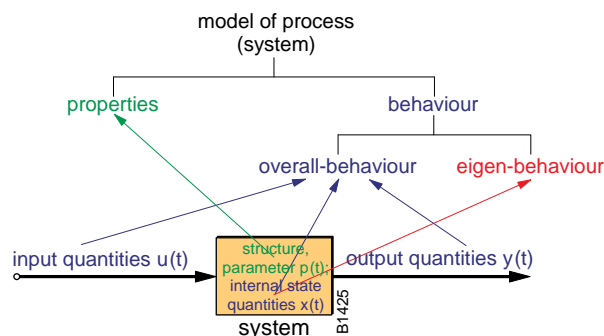

4.3. Intention to Measure

To anticipate future measurement tasks, we define *quantities intended to be measured* (measurands): input and output quantities. They are selected due to

added knowledge and further demands concerning the process [5].

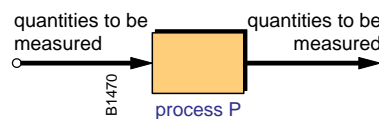

It is important to mention that normally some quantities intended to be measured, are *immeasurable quantities*, whatever the reasons may be, and there are many.

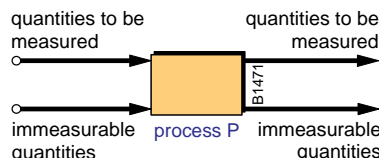

Fortunately, we have special tools in System Theory to handle those immeasurable quantities: For example, *closed loop observer* CLO and *unknown input observer* UIO [6] try to estimate immeasurable quantities via measurable quantities based on mathematical models and a-priori knowledge.

The definition of quantities to be measured in a process is not always straightforward, as it depends on the information, which should be accomplished. The following example exhibits a rather complex relationship between different physical quantities for the definition of two concentration quantities of humid gas in a vessel, intended to be measured in one or the other way. The set of equations, marked as process P here, is only in an abstract, but unambiguous manner related to physical reality.

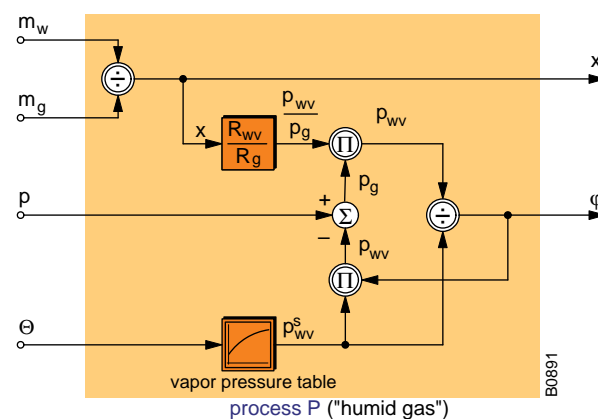

Quantities		
x	–	absolute humidity
φ	–	relative humidity
p	bar	pressure
θ	°C	temperature
Θ	K	absolute temperature
R	Jkg <sup>-1</sup> K <sup>-1</sup>	gas constant
m	kg	mass
Indices		
g		gas
w		water
wv		water vapour
s		saturated

#### 4.4. Model of the Measurement Process

Note that we have not established a connection to a *measurement process* up to now; we have only described a *process without instrumentation* and without quantities actually measured: The aimed for top-down approach says that the strategies to describe processes by mathematical modelling are always and everywhere the same. Therefore, specific tasks of Metrology add only specific concepts at most and not too many either.

Consequently, we first consider quantities again, now *quantities actually measured* (measurands)  $y(t)$  at the input, and *resulting quantities*  $\hat{y}(t)$  at the output of the measurement process M. One of the tasks of a measurement procedure is to relate them by formal logic or mathematical relations.

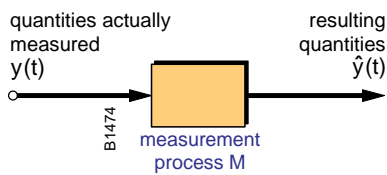

As soon as we know after an ordinary measurement procedure the resulting quantities  $\hat{y}(t)$  at the output, we want to infer to the unknown quantities at the input, *intended to be known* (measurands). For this purpose, we have to know the properties of the measurement process: We need some model for certain types of quantities, a mathematical model. In other words, there is no quantitative measurement without a mathematical model of the measurement process.

#### 4.5. Process Under Measurement

Before going into further details in this endeavour, we mentally connect process P and measurement process M. Originally, both sub-processes constituted a physical unit (process) of their own. Now they form a new process, the *process under measurement PUM*, and the properties of this combined process are decisive from now on. The *quantities intended to be measured* become *quantities actually measured*; that is crucial.

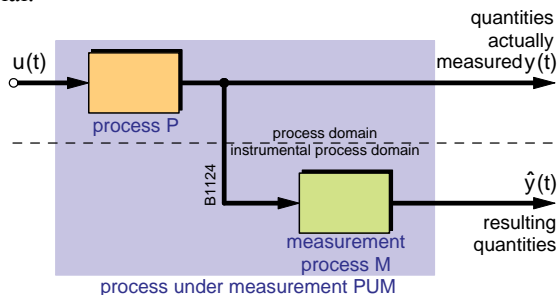

Now, the quantities of process P may be affected or disturbed by the insertion of sensors S, which are part of the measurement process M. One of the reasons is mass and/or energy removal, which goes with the withdrawal and transfer of *information*. This particular effect leads to systematic measurement errors,

so called loading errors, which often remain undetected: We say, it is due to a *nonideal measurement process*.

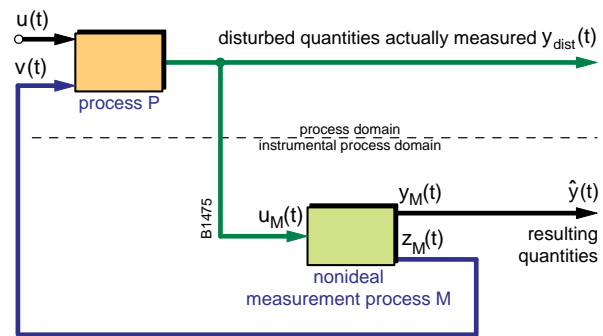

Mathematical modelling in a feed-forward strategy of the interconnected processes reveals and quantifies these effects and shows resulting errors and *uncertainties*. We already have mentioned that the measurement chain is not a chain at all, or, the chain is not non-reactive.

#### 4.6. Derived Quantities

There are quantities that exist only as definitions of two or more related quantities, described by abstract mathematical models. Prominent examples are area, power, performance, efficiency, error, dose equivalent of radiation, composition of matter and so forth.

The following example shows the objective of an indirect measurement. The relation between two power quantities  $P_i(t)$  and  $P_o(t)$  in a real physical process P, combined per definition in the virtual quantity efficiency  $\eta(t)$  cannot be measured directly.

Model-based measurement will help by means of a simple open-loop observer OLO. All indirect measurement problems are solved this way.

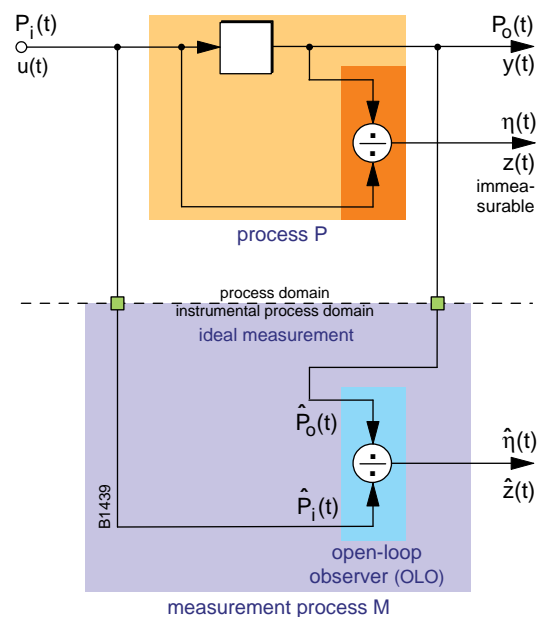

### 5. FUNDAMENTAL AXIOM OF METROLOGY

We have assigned input quantities (measurands and disturbances) and output quantities (resulting and loading quantities) to a measurement process M. For now we assume an *ideal measurement process* without disturbing and loading quantities. Additionally, we have to clarify the delicate situation that the quantities actually measured (measurands)  $y(t)$  are *physically not identical* with the resulting quantities  $\hat{y}(t)$ ; in the process domain they are not of the same type. However, it is evident that in the model domain the resulting quantities  $\hat{y}(t)$  have to equal the unknown measurement quantities  $y(t)$ , but only concerning numerical values and physical units. The *Fundamental Axiom of Metrology* expresses this special requirement and definition [19].

Definition: *Fundamental Axiom of Metrology*

$$\begin{aligned} \text{resulting quantities} &\stackrel{!}{=} \text{measured quantities} \\ &\text{numerically, or} \\ \hat{y}(t) &\stackrel{!}{=} \mathbf{I} y(t) \end{aligned}$$

This requirement leads directly to the basic condition for the properties of an ideal multivariable measurement process, which we call the *Nominal Measurement Process MN*. It directly affects the set of transfer response functions of the mathematical model.

Definition: *Transfer Response Function Matrix G of the Ideal Measurement Process MN*

$$\begin{aligned} \text{transfer response matrix} &\stackrel{!}{=} \text{unit matrix} \\ \text{or} & \\ \mathbf{G}_{\text{nom}} &\stackrel{!}{=} \mathbf{I} \end{aligned}$$

This condition is useful for any information acquisition strategy and for all types of process properties.

What is the corollary evolving by such trivial statements? At the front end of each measurement process M is the *sensor process S*, where the purely physical transformations takes place based on approved sensing principles and according to the objective *principle of cause and effect*. New physical quantities  $y_S(t)$  arise, typically electrical or optical ones. Normally we are not interested in those physical quantities. We look for symbols as results  $\hat{y}(t)$ , given as numbers with the appropriate units. They are information about the quantities  $y(t)$  of the process P.

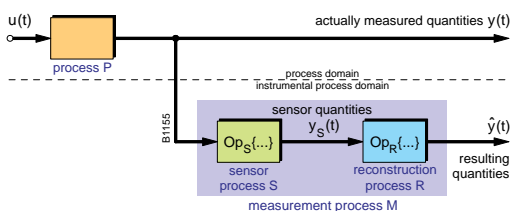

For this task, we need a sub-process, connected in series with the sensor process S. We call it *reconstruction process R* [4]. There we seemingly walk (look

back from the known sensor signals  $y_S(t)$  to the unknown measurement quantities  $y(t)$ . The reconstruction process R enables the fulfilment of the *Fundamental Axiom of Metrology* as soon as its *transfer response function* (operation, model) is realised as the *mathematical inverse* of the given transfer response function (operation, model) of the preceding sensor process S: As soon as  $Op_R\{\dots\} = Op_S^{-1}\{\dots\}$ , we get as desired  $Op_S^{-1}\{\dots\} \cdot Op_S\{\dots\} = \mathbf{I}$ .

Though the *Fundamental Axiom of Metrology* is extremely simple, its message is far-reaching. First, the axiom is already a *mathematical model*. Secondly, any *design of measurement process M*, even the simplest conceivable, must follow it. Most metrologists do not realise this rule, but they subconsciously follow it. Thirdly, we have an ingenious and efficient tool by the reconstruction process to influence the *overall behaviour of the measurement process M* in the intended direction. Fourthly, the concept is independent of *instrumental realisations* within the measurement process.

For practical applications the axiom states that in principle a *nonideal sensor behaviour* does not bother too much, provided the following reconstruction process is designed as defined without trade-offs, or, casually speaking, if the reconstruction process is “inverse nonideal”. Normally, we implement reconstruction processes in electronic circuits or in processors. These are much easier designed in an intended direction than physical sensor processes.

On the other hand, we all are aware that a reconstruction process is never realisable exactly. It is not possible. We cannot know the mathematical model of the sensor process completely in spite of careful *calibration* and *identification*. Additionally, unknown effects will interfere randomly. This highlights the importance of thorough modelling in Metrology.

Repeatedly we face the typical situation in Metrology of an *ideal world* of our imagination (nominal model), of a theory, if you want, and the situation of a *non-ideal world* of reality in practice (real model). An analysis of these discrepancies makes us aware, which errors and uncertainties will appear why and where in the *erroneous resulting quantities*. We may deduce hints, which help us to reduce their undesired influences.

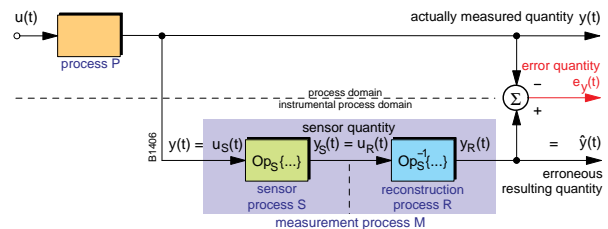

Let us take a simple example of a pressure sensor with an erroneous output current  $i_{se}$  [mA]. The error process E accompanies the sensor process. It is given only as a *calibration table* (look-up table), here described by a parallel structure, where the error  $e_i$  [mA] depends on the measurement quantity  $p$  [bar]. We

know that the inverse structure of a parallel connection is always a feedback connection [14], here with the model of the error process E (look-up table) placed in the feedback path of the reconstruction process. Note the eye-catching *symmetric structure* of the entire process due to the inversion concept.

Let us consider an example to visualise mathematical models (characteristic values and characteristic functions) of a random, time dependent quantity *pressure*  $p(t)$  [bar]. Which of the characteristic items we have to choose and to use, depends strongly on the requirements of a given task.

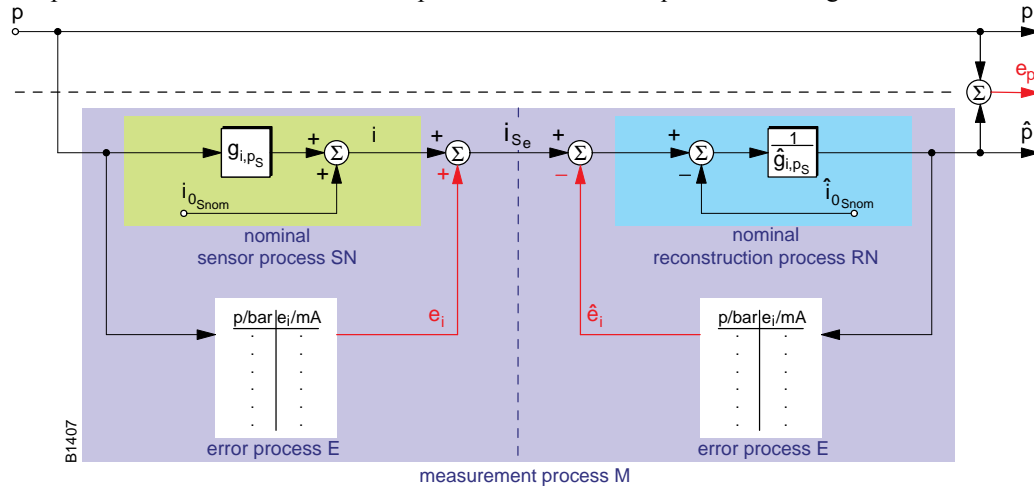

A last remark: If the sensor process is a dynamic one, which is normally the case, we design the reconstruction process R again by the inversion of the sensor model: *Inverse Dynamics*. Admittedly, the realisation can be troublesome but is not impossible.

6. MATHEMATICAL MODEL OF A QUANTITY

Normally we speak about models of *processes* only; those of *quantities* are important as well. Again, mathematical models of quantities, depending on time and space, describe them using all types of mathematical tools in different domains. Again, the *structures* and *parameters* of the mathematical tools represent the *properties* of quantities. It sounds funny, but quantities do not have an own behaviour unlike processes, because they emerge from processes with behaviour. To simulate quantities with desired properties, we produce them by processes, filters for example, with a dedicated behaviour.

It is quite simple to describe deterministic quantities; it is less straightforward to describe random ones. If we move to the probabilistic domain, we can describe them too, not as distinct events, but in an average sense, treating them as samples of ensembles. We call these mathematical models *characteristic values* and *characteristic functions*. If we have such a mathematical model, often in form of the *probability density function*, we may use all tools of System Theory to describe the propagation of these random quantities through processes. This is mandatory for a quantitative treatment of *random measurement errors* and *uncertainties*.

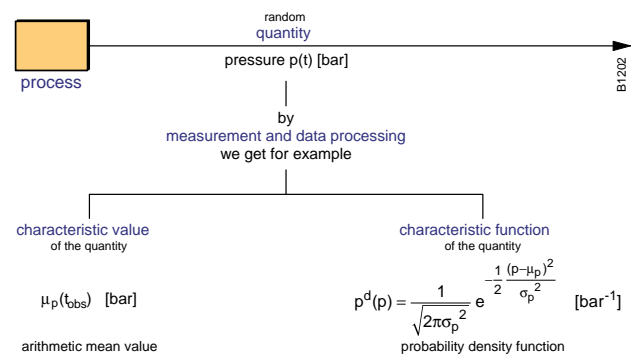
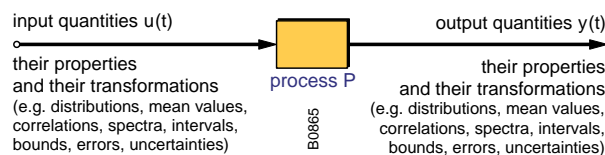

Mathematical relations *between* quantities within a group lead to *joint values* and joint functions respectively. Relations *across* groups lead to *cross values* and *cross functions*, describing the process between the groups. They are tools to describe dependencies between measurement errors and uncertainties too. The following graph visualises the formation of a matrix of characteristic joint and cross functions.

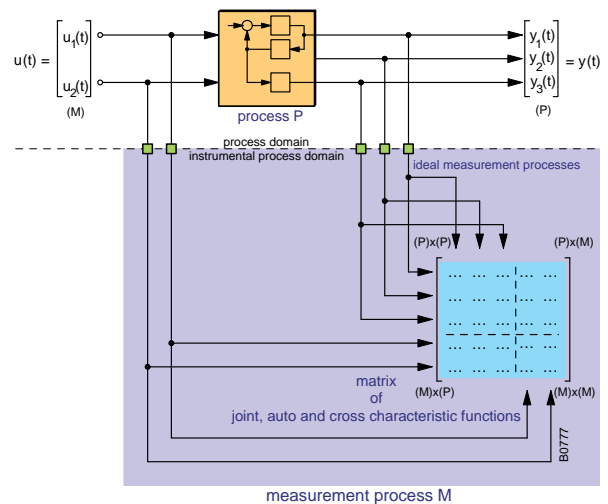

## 7. CONTROLLED PROCESS – MATHEMATICAL MODELS EVERYWHERE

The measurement process M is always only a sub-process of a larger process. There is of course the process of interest P. Its counterpart is the control process C, in which the human being is involved mostly. The twin of the measurement process M is the actuation process A. Let us call the whole entity *controlled process* CP. There are *interconnections* (functional in the process domain) and *interrelations* (*relational* in the model (system) domain) respectively, called *interfaces* or *links*, always in both directions due to several reasons. In technology, actuators and sensors assume the linking task directly. This is a universally valid structure. We may it reduce to serve simpler needs. Again, starting with the well-defined input-output structure, we combine mathematical models of the sub-processes to the overall model, which enables simulation of the whole process. Note the apparent symmetry.

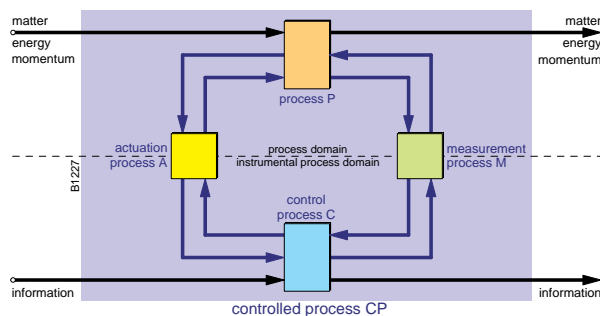

It should be mentioned that such a controlled process CP has to be provided necessarily in its full structure, as soon as a process to be observed P must be stimulated, in order to trigger measurable quantities. The actuation process A will care for the required power. Examples come from many fields like optical measurement, ultrasonic measurement, magnetic resonance imaging (MRI), spectroscopy measurements of many types, impedance measurement, and so on.

We also should observe that all *calibration* and *identifying processes* reveal this structure too. The measurement process to be calibrated is the process P now: Again, no calibration without mathematical models!

Finally, we have arrived at *Metrology in the Loop* with all demands but also with all tools, which the *control community* has established up to now. We should take advantage of the opportunity to join their systematic and useful construct of ideas and to help expanding the fascinating building.

## 8. CONCLUSION

A given model, as a mental product of the human being, represents knowledge about a thoroughly defined part of reality. We call the chosen part of reality «process» with «quantities» and the corresponding model «system» with «signals». The given model, de-

signed to serve a specific objective, describes properties and behaviour of the process only to a certain extent due to different reasons. The knowledge may be of any type, particularly of a qualitative and/or of a quantitative type. The tools Signal Theory and System Theory are able to handle models in an extremely simple as well as in a most sophisticated manner.

It is our firm belief, and this is of course a vast claim, that these statements apply to all definable realities (processes with quantities), which belong to diversified fields like natural and technical sciences, medical sciences, economical and financial sciences, social sciences, psychological sciences and so on.

Measurement Science and Technology use mathematical models nearly everywhere. Often they are not recognised as such. The top-down approach is independent from any instrumental realisation.

## 9. REFERENCES

- [1] K. H. Ruhm, "What is Metrology", IMEKO Bulletin No. 48, Vol. 37, No. 1, 2009, pp. 18 - 24 ([http://www.imeko.org/download/bulletin\\_48.pdf](http://www.imeko.org/download/bulletin_48.pdf))
- [2] L. Finkelstein, "Measurement and Instrumentation Science and Technology – The Educational Challenges", Journal of Physics: Conference Series, 238 (2010) 012001, pp.1 – 6, (<http://iopscience.iop.org/1742-6596/238/1/012001>)
- [3] F. Abdullah, L. Finkelstein, S. H. Khan, W. J. Hill, "Modelling in Measurement and Instrumentation – An Overview", Measurement 14 (1994) 1, pp. 41 - 53
- [4] R. Z. Morawski, "Unified Approach to Measurand Reconstruction", IEEE Transactions on Instrumentation and Measurement, vol. 43, no. 2 (1994) pp. 226 - 231
- [5] VIM, "International Vocabulary of Metrology – Basic and General Concepts and Associated Terms" (abbreviated VIM3), BIPM, Paris, JCGM 200:2008 (2008; edition 3); Corrigendum (May 2010) (<http://www.bipm.org/en/publications/guides/vim.html>)
- [6] P. H. Sydenham, "Structured Understanding of the Measurement Process" – "Holistic View of the Measurement System (Part 1)" and "Development and Implementation of a Measurement Process Algorithm (Part 2)", Measurement 3 (1985) 3 / 4, pp. 115 - 120 / 161 - 168
- [7] R. Thorn, N. H. Hancock, P. H. Sydenham, "Measurement Science versus Measurement Technology in the Engineering Curriculum", Engineering Science and Education Journal, June 1997, pp. 113 - 118
- [8] F. Mesch, "Didactic reduction by theory, with special attention to measurement education", Measurement 14 (1994) 1, pp. 15 – 22
- [9] T. S. Kuhn, "The Function of Measurement in Modern Physical Science", Isis, vol.52, no. 2, 1961, pp.161 – 193 (<http://www.jstor.org/stable/228678>)
- [10] D. H. Krantz et al., "Foundations of Measurement", Volume I, Academic Press, NY (1971)
- [11] K. H. Ruhm, "Process and System – A Dual Definition, Revisited with Consequences in Metrology", Journal of Physics: Conference Series 238 (2010) 012037 (<http://iopscience.iop.org/1742-6596/238/1/012037>)
- [12] D. Hinrichsen, A. J. Pritchard, "Mathematical Systems Theory I – Modelling, State Space Analysis, Stability and Robustness", Springer (2005)

- [13] René Dybkaer, “Metrology and Protometrology: The Ordinal Question”, *Accreditation and Quality Assurance* (2007) 12, pp. 553–557
- [14] K. H. Ruhm, “Inversion of Interconnected Systems” (2008)  
(<http://www.mmm.ethz.ch/dok01/d0000819.pdf>)
- [15] K. H. Ruhm, “Structures and Parameters of Signals” (2005)  
(<http://www.mmm.ethz.ch/dok01/d0000546.pdf>)
- [16] K. H. Ruhm, “Process and System – A Survey” (2008)  
(<http://www.mmm.ethz.ch/dok01/d0000861.pdf>)
- [17] K. H. Ruhm, “Quantity and Signal – A Survey” (2008)  
(<http://www.mmm.ethz.ch/dok01/d0000856.pdf>)
- [18] K. H. Ruhm, “Basic Structures of State Space Description” (2005)  
(<http://www.mmm.ethz.ch/dok01/d0000532.pdf>)
- [19] K. H. Ruhm, “Science and Technology of Measurement – A Unifying Graphic-Based Approach”; 10<sup>th</sup> IMEKO TC7 International Symposium, St. Petersburg, Russia (2004)  
(<http://www.mmm.ethz.ch/dok01/d0000742.pdf>)

---

**Author:** Karl H. Ruhm, Senior Lecturer, Institute of Machine Tools and Manufacturing (IWF), Swiss Federal Institute of Technology (ETH), Tannenstr. 3, CH 8092 Zurich, Switzerland, Phone: +41 44 632 2463, Fax: +41 44 632 1125, Email: [ruhm@ethz.ch](mailto:ruhm@ethz.ch)