

# Interacting with real time simulations – virtual reality in industry applications

A. Jönsson<sup>1</sup>, J. Bathelt<sup>2</sup> and G. Broman<sup>1</sup>

<sup>1</sup> Department of Mechanical Engineering, Blekinge Institute of Technology, Karlskrona, Sweden  
<sup>2</sup> Centre of Product Design, Swiss Federal Institute of Technology, Zurich, Switzerland

---

## Abstract

*Modern manufacturing machines are highly multidisciplinary, and with demands on short time-to-market, product development based on traditional prototype testing has become impractical. By using virtual models, it is possible to test large numbers of variants and optimise the product with the aid of a minimum of physical prototypes. Due to the immense development of software and hardware for simulation and visualisation it should today be possible also for small and medium sized enterprises to use methods that just few years ago were too expensive and complicated. There is however still a great need for building knowledge and competence. This work is an early step in a project aiming at a virtual water jet cutting machine to be used by the industrial partner for optimisation during the development process. The possibility of performing real-time simulations of this machine in a virtual environment, using a normal PC and commercial software, will be investigated. Initially strongly simplified models of the system components are used and the focus is on the overall system model and the interaction between the operator and the virtual machine. It is shown that real-time interaction is possible with this system and with the obtained flexibility of the overall virtual model it should be easy to include more realistic component models for improved accuracy in future work. Preliminary results indicate however that to include, for example, flexibility within the mechanic structure, component modelling will be delicate. These models must describe relevant characteristics accurately enough while still being computationally effective enough for real-time interaction and systems optimisation to be possible. This will probably be a challenge in the continuation of the project, even with an expected continued strong development of computer capacity.*

## Keywords:

*Control system, industrial application, multi-body system, real-time simulation, user interface*

Categories and Subject Descriptors (according to ACM CSS): I.3.7 [Computer Graphics]: Virtual Reality; I.3.8 [Computer Graphics]: Applications; J.7 [Computer Applications]: Industrial Control

---

## 1. Introduction

The industrial partner, Water Jet Sweden AB, Ronneby, Sweden, has extensive experience of water jet cutting machines and the process in which these products are used. Although already being one of the leading fabricators in the world, market demands puts continuous pressure on the company to develop new machines, having even higher efficiency and precision. To keep or strengthen competitiveness, cooperation between the company and the Department of Mechanical Engineering, Blekinge Institute of Technology, Karlskrona, Sweden, has been initiated for mutual transfer of knowledge and generation of compe-

tence in using modern aids for product development. The long-term goal is a virtual machine to be used by the company for multidisciplinary systems optimisation. The possibility of performing real-time simulations of a water jet cutting machine in a virtual environment, using a normal PC and commercial software, will be investigated.

In this work strongly simplified models of the system components are used. The focus is on the overall system model and the interaction between the operator and the virtual machine. Similar work is described in references <sup>1</sup>; <sup>2</sup>. In <sup>1</sup>, the focus is on event-based simulations, and in <sup>2</sup>, the focus is on the control system.

## 2. Multidisciplinary system

The multidisciplinary system is schematically illustrated in Figure 1. Principally it consists of a system environment, which is interacting with a mechatronic system via an interface.

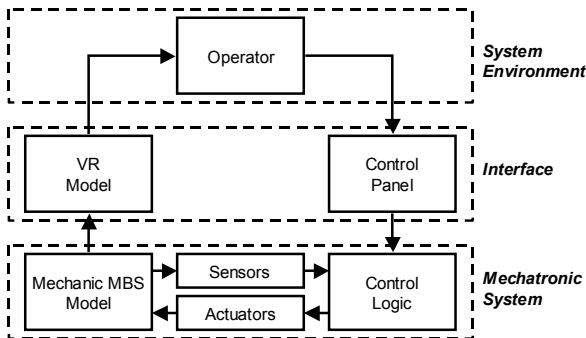

Figure 1 Description of simulated system.

Generally the system environment and the mechatronic system can be both analogue and digital. For example, the mechanic structure of a real machine is analogue, but the part simulated as a system of rigid bodies is digital.

In this work, the system environment only consists of an operator, so all interaction with the interface is analogue. The mechatronic system consists of control logic, actuators, sensors and a multi-body system (MBS) model of the mechanic structure, and it is purely digital. The interface consists of the control panel and the visual output from the virtual reality (VR) model. The interface has to be able to handle both analogue and digital information.

Linear slider potentiometers on the control panel are used to give the reference input for the position of the two main operating axes of the machine to the simulated control logic. A standard soundcard on the PC does the analogue to digital conversion.

The mechatronic system is mainly simulated inside Simulink. The control logic is modelled as a PID-control. The control logic gives input to the simulated actuators, which affects the mechanic structure. The actuators and sensors are idealised, but it is possible to include more realistic characteristics in future work. The mechanic structure is modelled with the toolbox SimMechanics.

## 3. Results and discussion

It is possible to run this simplified model on a normal PC in real-time. It is easy for the operator to see the reaction of the system in the virtual environment as a result of his input. The operator can easily use different points of view to have a closer look at the behaviour and it is possible to add extra feedback by scaling the motion of the machine. The virtual model also makes it possible to get an early notice if there is unreasonable behaviour. Furthermore, it should be possible to use for early training of operators, marketing and design reviews. So, already such a rough model is capable of giving important information during product development and it is interesting that this type of multidisciplinary simulations are today affordable for small and medium sized enterprises. There is however still a great need for building knowledge and competence to get a major breakthrough in this sector.

Simulating all parts of the mechatronic system within a Matlab/Simulink environment simplifies the coupling between the different software and still provides high flexibility. As regards the overall virtual model it should be easy to include more realistic component models for improved accuracy. Preliminary results indicate however that to include, for example, flexibility within the mechanic structure, component modelling will be delicate. These models must describe relevant characteristics accurately enough while still being computationally effective enough for real-time interaction and systems optimisation to be possible. This will probably be a challenge in the continuation of the project, even with an expected continued strong development of computer capacity.

### Acknowledgments

Financial support from the Swedish Foundation for Knowledge and Competence Development and Water Jet Sweden AB is gratefully acknowledged.

### References

1. S. Dierssen. Systemkopplung zur komponentenorientierten Simulation digitaler Produkte, Fortschr.-Ber., VDI Reihe 20 Rechnerunterstützte Verfahren, Nr. 358 VDI-Verlag, Düsseldorf, 2002.
2. K. Kreuzschm. Verifikation numerischer Steuerungen an Virtuellen Werkzeugmaschinen, Berichte aus der Steuerungs- und Regelungstechnik, Shaker Verlag, Aachen, 2002.