

SIMULATION AND PREDICTION OF THE THERMALLY INDUCED DEFORMATIONS ON MACHINE TOOLS CAUSED BY MOVING LINEAR AXIS USING THE FDEM SIMULATION APPROACH

Josef Mayr¹, Markus Ess¹, Sascha Weikert¹, Konrad Wegener¹

¹Institute of Machine Tools and Manufacturing
Swiss Federal Institute of Technology (ETH)
Zurich, Switzerland

ABSTRACT

In this study the structure of a machine tool is analyzed using the Finite Difference Element Method (FDEM) simulation approach. This approach for the computation of thermally induced displacements of machine tools structures is characterized by using finite differences for the temperature field and based on that finite elements for the thermoelastic displacements. The simulation results are verified via measurements of displacement and temperatures in a test according to ISO 230-3.

INTRODUCTION

The thermo-elastic deformations of machine tools caused by internal and external heat sources largely contributes to the overall geometrical inaccuracies of the workpiece [2]. Machine tool manufacturers therefore deem thermal displacements as the the most important task towards better accuracy. Therefore thermal simulation of machine tools moved increasingly into the foreground of newer research activities. The "Thermal Effects Diagram" [1] knows six sources of thermal influences of machine tools:

- heat generated from the (cutting) process
- heat generated by the machine
- heating or cooling influence by the various cooling systems
- heating or cooling influence provided by the room
- the effect of people
- thermal memory from any previous environment

In this study an example is given to calculate effects of heat generated by the machine. The example describes a way to calculate the thermally induced deformations of machine tools by a moving linear axis. In standards like the ISO 230-3 or the ANSI/ASME B5.54 procedures to determine the thermo-mechanical behavior of

machine tools under different thermal load cases [3,4] are described.

Due to the increase of computational power the Finite Element Method (FEM) becomes increasingly important for the simulation of the thermal behavior of machine tools. The Finite Differences Method (FDM) is often used to numerically solve temperature and flow field problems with the advantages that the models can easily be established and programmed, and the solving speed is high [10]. Using a Modified Lumped Capacitance Method (MLCM) the heat flow in a ball screw and a feed drive system has been solved [5,6]. Bearings have also been included into the simulation model of a ball screw system, as they influence the temperature distribution by producing frictional heat [7].

FDEM

The FDEM is an alternative way of simulating the transient thermal behavior of mechanical systems such as machine tools. The FDEM is a simulation approach that combines the advantages of FDM and FEM. In the first step the 3-D temperature distribution at discrete time points is calculate using FDM. In a second step the thermal deformations at the discrete time points are calculated using FEM. The temperature distribution at the discrete time points of the earlier FDM was used as temperature field for the FEM. Thus the FDEM can be seen as a serial simulation approach. The most advantage is that the method is very efficiently with short calculation time [8].

MACHINE TOOL MODEL

A simplified model of a small three axes milling machine representing the thermal and mechanical behavior of the whole machine tool with less than 5'000 Elements was developed. FIGURE 1 shows the model of that milling machine. Material properties are an important factor in retrieving accurate simulation results. Values as Young's modulus (E), shear modulus (G) and

Poisson-ratio (ν) are important for describing the elastic behavior, while the coefficient of linear thermal expansion (α), the heat conductivity (λ) and the heat capacity (c_p) are important for the thermal behavior.

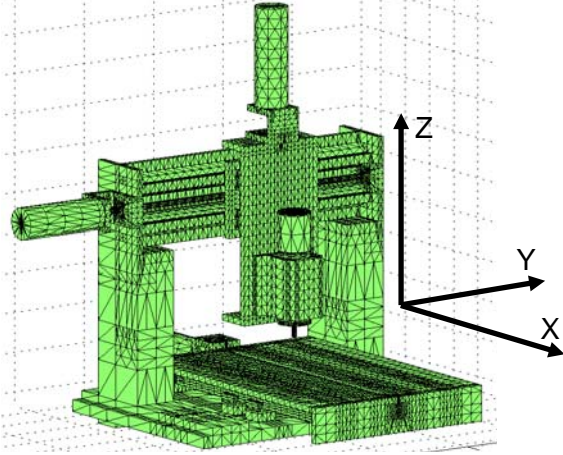

FIGURE 1. Model of the three axes machine tool with about 5'000 elements.

Bearings

The dimension of bearing models does not match with the bearings in detail. Therefore the material properties need to be adjusted. For example the density (ρ) can be adjusted to compensate the heat capacity of the whole bearing of mass m :

$$\Delta Q = \rho \cdot V \cdot c_p \cdot \Delta T = m \cdot c_p \cdot \Delta T \quad (1)$$

Therefore if the volume of the components model is not equal to the real components volume we can change c_p or ρ to compensate for heat storage. In this study we changed ρ in the following way:

$$\rho = \frac{V_{\text{model}} \cdot \rho_{\text{real}}}{m_{\text{real}}} \cdot \rho_{\text{real}} \quad (2)$$

m_{real} : mass of the real bearing

The mechanical material properties are also adjusted. For example the elastic coupling in axial direction of the floating bearings is modeled by setting the shear modules in the axial direction close to zero. FIGURE 2 illustrates the shear planes of the y-axis ball screw floating bearing. At this bearing the shear modules G_{xy} and G_{yz} are set close to zero. Similarly for the floating bearings of the x-axis ball screw the shear modules G_{xy} and G_{xz} and for the z-axis ball screw the shear modules G_{yz} and G_{xz} are set close to zero.

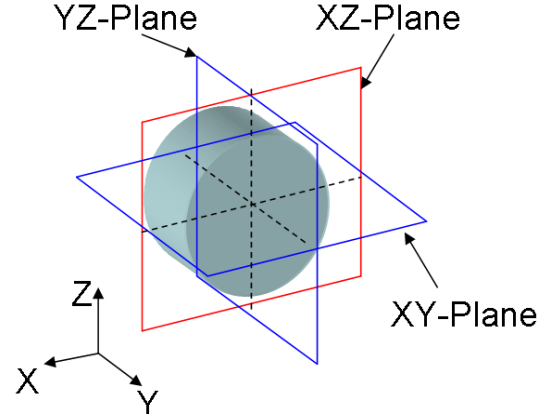

FIGURE 2. Shear planes of a bearing of the y-axis ball screw.

HEAT SOURCES

During a cyclic motion of a linear axis the actual forces are changing according to the actual state of motion. For example when the linear axes are moving with constant velocity only external forces caused by friction are acting. Other examples are forces acting because of increasing/decreasing velocity during acceleration/deceleration. The contribution of the different forces acting on the system during a cycle to the averaged force is proportional to their time duration.

$$F_{\text{external}} = \sum_i \frac{F_i \cdot t_i}{t_{\text{cycle}}} \quad (3)$$

Ball Screw and Ball Screw Nut

The losses in a ball screw system are given by:

$$P_{\text{ball screw}_{\text{tot}}} = \frac{F_{\text{external}}}{\cos^2(\varphi_{\text{nut}}) \cdot \sin(\alpha_{\text{nut}})} \cdot \mu_{\text{nut}} \cdot d_b \cdot \pi \cdot n + \frac{T_{\text{no_load}} \cdot n \cdot 2 \cdot \pi}{n \cdot 2 \cdot \pi} \quad (4)$$

d_b : ballscrew pitch diameter

μ_{nut} : friction coefficient of the ball screw nut

φ_{nut} : lead angle of the ball screw

α_{nut} : contact angle of the ball screw

$T_{\text{no_load}}$: idle torque

Equation 4 has two parts: The first part describes losses acting because of external forces. The second part describes losses due to idle torque of the ball screw system.

The heat distribution between the ball screw and ball screw nut is determined using the following procedure:

- measurement of the ball screw nut temperature during a given state of motion
- calculating the losses of the ball screw system using (4)
- calculating the heat stored in the ball screw nut using (1), assuming the heat losses from the balls to air are negligible
- find distribution factor $\xi_{ball\ screw}$

$$P_{ball\ screw} = \xi_{ball\ screw} \cdot P_{ball\ screw_tot} \quad (5)$$

$$P_{nut} = (1 - \xi_{ball\ screw}) \cdot P_{ball\ screw_tot} \quad (6)$$

NUMERICAL SIMULATION

To have a basis to compare simulations with measurements the load cases used in this study are load cases described in the ISO standards. Three different simulations according to the ISO 230-3 chapter 7: "Thermal distortion caused by moving linear axes" are done. The thermal distortions caused by moving the y-axis with constant velocity have been simulation. The feed rates chosen for simulation are:

- 2500 mm/min, 25% of fast motion
- 5000 mm/min, 50% of fast motion
- 7500 mm/min, 75% of fast motion

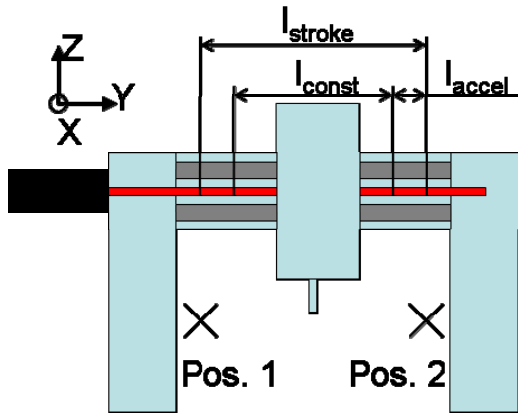

FIGURE 3. y-axis ball screw, Pos.1 and Pos.2: measurement positions.

Implementation of the Movement

In FIGURE 3 the configuration of the y-axis portal under investigation is shown. Pos.1 and Pos.2 are the measuring points. During the oscillating movement, between the measuring points, the y-axis ball screw nut travels along the ball screw over a distance l_{stroke} . During acceleration/deceleration the ball screw nut travels along the ball screw over a distance l_{accel} . Therefore the distance l_{stroke} is cut into three parts: l_{accel} , l_{const} , l_{accel} .

The boundary conditions and losses for the elements of the ball screw which are connected in l_{stroke} have to be modified.

$$P_{ele} = \left(\frac{P_{accel} \cdot l_{accel} + P_{const} \cdot l_{const}}{l_{ele}} \right) \cdot \frac{t_{ele_tot}}{t_{cycle}} \quad (7)$$

l_{accel} , l_{const} : length described in FIGURE 3

t_{cycle} : time for a single cycle

t_{ele_tot} : contact time of nut and ball screw element

Equation 7 gives an example of the heat input into an element of the ball screws model which is part of l_{accel} and l_{const} . The convective boundary conditions of this element have been modified using equation 8.

$$\alpha_{ele} = \frac{t_{cycle} - t_{ele_tot}}{t_{cycle}} \cdot \alpha_{cal} \quad (8)$$

α_{cal} : convective boundary coefficient

RESULTS AND DISCUSSION

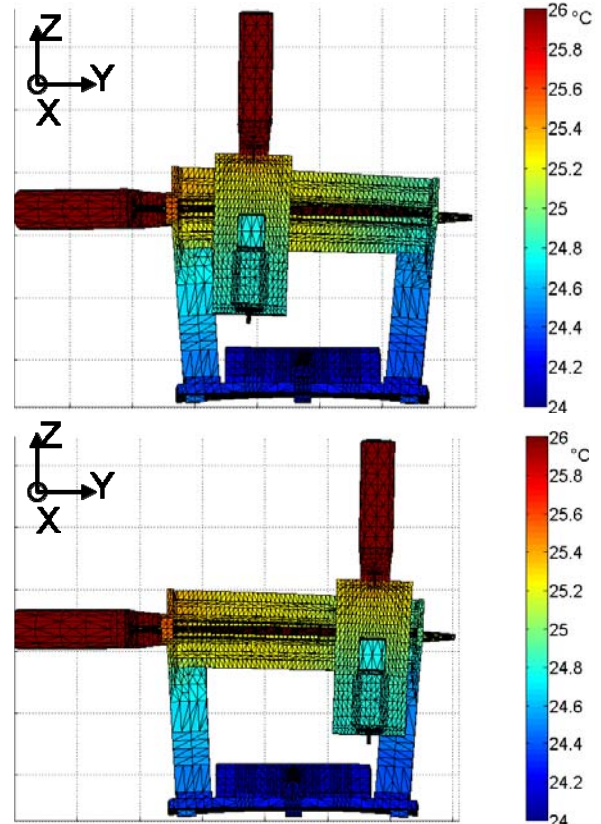

FIGURE 4. Simulation results: Temperature distribution and deformation, scale factor 10'000, steady state, top: Pos. 1, bottom: Pos.2.

All diagrams in this chapter are taken from the load case of the y-axis oscillating with 5'000 mm/min over 265 mm. FIGURE 4 shows the calculated temperature distribution and deformation of the machine tool model in the measurement positions Pos.1 and Pos.2 in steady state. The colorbar shows the temperature values for the temperature distribution. Some parts of the machine tool are being heated to more than the maximum temperature in the colorbar, e.g. the y-axis ball screw and the motors.

The transient simulations help to understand the thermal behavior of machine tools in detail. FIGURE 5 shows for example the displacement in y-direction of the TCP(tool centre point). In the first two hours the TCP-displacement caused by deformation on the tool side dominates the overall TCP-displacement.

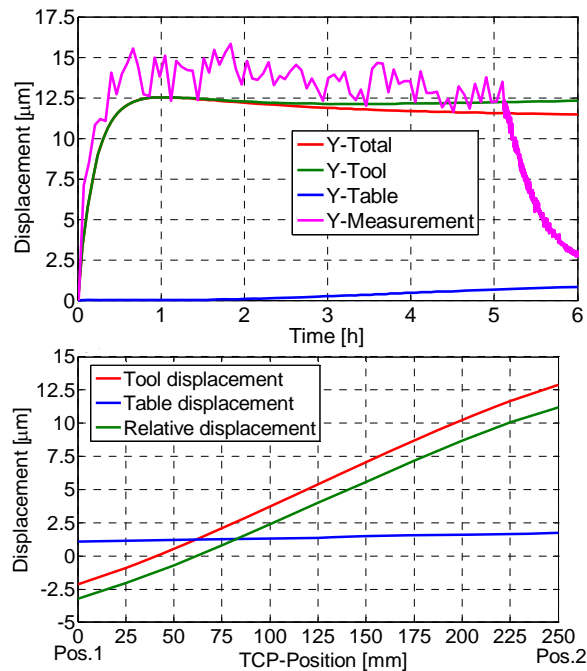

FIGURE 5. top: y-direction TCP-displacement in Pos.2, simulation and measurement, bottom: y-direction TCP-displacement for a virtual movement along the y-axis, Y-tool/YTable: TCP-displacement on the tool/table side.

Later, enough heat was flowing from the y-axis portal into the x-axis table. The table starts to grow and influences the TCP-displacements, shown in FIGURE 5, top as Y-Table.

In FIGURE 5, bottom the calculated y-direction TCP-displacement for a virtual movement cycle along the y-axis between Pos.1 and Pos.2 in steady state is shown. Because of warming the portal through oscillating y-axis the columns are

bending outside. Therefore the TCP-displacements at Pos1 in y-direction are negative. The simulation results in FIGURE 5, bottom show that at about 30 mm the TCP-displacement turns into positive. The reason for this asymmetric behavior is the lengthening of the ball screw and portal.

ACKNOWLEDGEMENT

The Authors like to thank BBT for financial support.

REFERENCES

- [1] Bryan J. International Status of thermal Error Research. Annals of the CIRP. 1990, 39/2. 645-656
- [2] Weck M, McKeown P, Bonse R, Herbst U. Reduction and compensation of Thermal Errors in Machine Tools. Annals of the CIRP. 1995, 44/2. 589-598
- [3] International Standard 230-3 2001: Test code for machine tools- Part 3: Determination of thermal effects
- [4] ANSI/ASME B5.54 1991: Methodes for Performance Evaluation of Computer Numerical Controlled Machining Centres
- [5] Kim S-K, Cho D-W. Real-time estimation of temperature distribution in a ball screw system. Int. Jour. of Machine Tools and Manufacturing. 1997, 37/4. 451-464
- [6] Yun W-S, Kim S-K, Kung Y-T. Thermal error analysis for a CNC lathe feed drive system. Int. Jour. of Machine Tools and Manufacturing. 1999, 39/7. 1087-1101
- [7] Horejs O. Thermo-mechanical model of the ball screw with non-steady heat sources. Int. Con. on Thermal Issues in Emerging Technologies: Theory and Application. 2007, 133-137
- [8] Mayr J, Weikert S, Wegener K. Comparing the thermo-mechanical-behavior of machine tool frame designs using an FDM-FEM simulation approach. Proceedings ASPE 2007 Annual Meeting. 2007, 17-20
- [9] VDI-Gesellschaft für Verfahrenstechnik und Chemieingenieurwesen. VDI-Wärmeatlas, 10. Auflage. Springer Verlag Berlin Heidelberg New York. 2006
- [10] Xue X, Tian J, Xui G. Numerical Simulation of Thermal Stress in Castings Using FDM/FEM Integrated Method. Material Science Forum 2005, 490-491. 85-90
- [11] Harris T-A. Roller Bearing Analysis, Second Edition. Wiley-Interscience New York Chichester Brisbane Toronto Singapore. 1984